

DEVAR Inc.

706 Bostwick Ave., Bridgeport, CT 06605

Tel 203 368 6751 Fax 203 368 3747

<http://www.devarinc.com> e-mail: info@devarinc.com

18-115A ISOLATED SENSOR TRANSMITTER

INSTRUCTION MANUAL



Manual #990597A

TABLE OF CONTENTS

<u>SECTION</u>	<u>TITLE</u>	<u>PAGE NO.</u>
I	General Description	1
II	Specifications	2-3
III	Installation	4-6
IV	Recalibration	7-11
V	Troubleshooting	12-14
VI	Parts List	15-17

LIST OF TABLES AND ILLUSTRATIONS

<u>FIGURE</u>	<u>TITLE</u>	<u>PAGE NO.</u>
3-1	Outline Dimensions - Transmitter Case	4
3-2	Outline Dimensions - Transmitter Case with Mounting Bracket (M31)	5
3-3	Outline Dimensions for Transmitter Case with Mounting Bracket, Terminal Cover (M32)	5
3-4	External Wiring of Different Types of Input Signals	6
3-5	Field Wiring Terminals.	6
4-1	Summary of a Major Calibration Change	7
4-2	Examples of Zero Offset and Input Span Settings Using Digital Switches	8
4-3	Calibrating Resistors for Various Types of Input	8
4-4	Calibrating Resistors for Voltage or Current Outputs	9
4-5	Calibrating Resistors for Single or Dual RTD or a Variable Resistor	9
4-6	Calibrating Resistors for Voltage Divider or Current Input	9
4-7	Reference Junction Compensating Resistor Table	10
4-8	Examples of Calculating the Offset Correction	10
4-9	Location of Calibration Components and Adjustments	11
5-1	Schematic, 18-115A Transmitter	13
6-1	Parts Locations, 18-115A Transmitter P.C. Boards	17

SECTION I
GENERAL DESCRIPTION

- 1.1 The 18-115A Isolated Transmitter receives a millivolt signal and converts it to a current or a voltage output completely isolated from the input and line power.
- 1.2 It is designed to operate from 115VAC or 230VAC line power. A power transformer isolates the power source from the input, output circuitries, and the excitation voltage.
- 1.3 The 18-115A accepts a variety of inputs such as millivolt source, thermocouple, single or dual RTD, strain gage, or a high level DC signal.
- 1.4 The input signal is amplified by a precision operational amplifier. The output of the amplifier is conditioned by a ten segment linearizing circuit (optional). This circuit linearizes the amplifier output with respect to the sensed temperature. The output of the linearizing circuit goes to a pulse width modulator which drives an optical isolator.
- 1.5 An optical isolator provides isolation between input and output circuits. The output of the optical isolator goes to an RC averaging circuit which yields a DC output proportional to the input signal. This DC output drives either a current or a voltage output stage. The current output stage is provided with a current limiting circuitry.
- 1.6 The 18-115A Isolated Transmitter uses digital switches for zero and span settings, eliminating the need for changing the span resistor (R110) and the zero trim resistor (R113). The digital switches provide a 0 to $\pm 63.5\text{mV}$ zero adjustment at a resolution of 0.5mV , and a 2 to 126mV span adjustment at a resolution of 2mV . In addition to the digital switches, multiturn trimpots provide $\pm 25\%$ zero and span adjustability for final calibration.
- 1.7 Reference junction compensation is offered for a variety of thermocouples. A resistor is selected to provide compensation for type J, K, T, R, S, or E thermocouples. Thermocouple break indication can be selected to be either upscale or downscale.

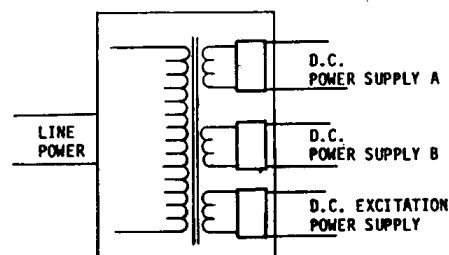
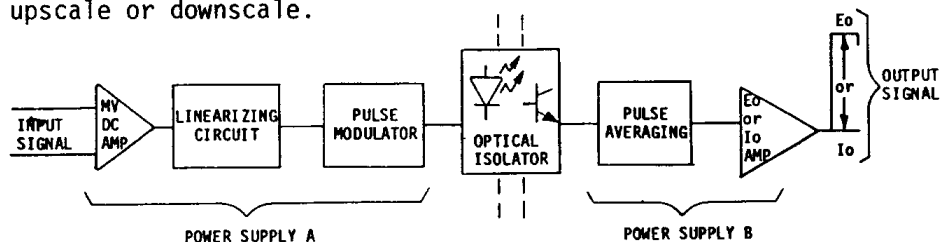

SECTION II
SPECIFICATIONS

2.1-General

A-Power requirements	115VAC at 60Hz, 7VA 230VAC (optional)
B-Common mode rejection ratio	Infinite at DC 160 db min, at 60Hz
C-Accuracy	0.1%, output proportional to mV input signal
Linearized option: 0.1% plus 10 to 1 improvement of nonlinear signal	
D-Overshoot (Response to input step)	None
E-Bandwidth	1 Hz
F-Time Constant	150 msec
G-Input Output isolation	500VDC
H-Supply regulation	0.01%/V between 105 and 125VAC
I-Excitation supply	1) +10VDC at 57mA max. for RTD and strain gage excitation. 2) Line regulation: 0.01%/V between 105 and 125VAC 3) Thermal error: 0.015%/°C Max.
J-Weight	1 LB

2.2-Input

A-Span	2 to 126mV
B-Offset	0 to \pm 63.5mV
C-Source Current	10nA typical, 28nA max. 100nA typical with T.C. Break
D-Leakage resistance	> 20,000 Mohm @ 200VDC

2.3-Outputs

A-Voltage output levels and minimum load resistance

0-10VDC at 1K ohms
0-5VDC at 500 ohms
1-5VDC at 500 ohms

B-Current output levels and maximum load resistance

1-5mA at 3K ohms
4-20mA at 750 ohms
10-50mA at 300 ohms

C-Temperature coefficient of output

0.01% per °C plus 1uV per °C referred to input
T.C. compensated: Add 1uV per °C

D-Output noise

Flicker noise: 1uV P-P, typical referred to input
other noise: 0.1% P-P, of full scale output level, maximum

2.4-Options

A-18-115A-L, Linearized

Accuracy 0.1% plus 10 to 1 improvement of nonlinear signal

B-18-115A-POT, potentiometer input

Accepts potentiometers from 0/200 ohms to 0/10,000 ohms

C-18-115A-E114, high level millivolt input

Extends offset and span by a factor of X10
Span to 1,260 mv
Offset to ±635 mv

D-18-115A-E139, high input impedance

Input impedance 10^{12} ohms, minimum

E-Readjust. Excitation supply from 10V to a voltage between 8 to 14V

8V at 67mA (Isolated Excitation supply for 120 ohm strain gage)
14V at 20 mA (Isolated power source for a 2 wire transmitter)

SECTION III

INSTALLATION

- 3.1 FIG. 3.1 shows the outline dimensions of the 18-115A isolated sensor transmitter. The mounting bushings are spaced according to Devar, Inc. module mounting standards. This permits the use of available hardware for installation with Devar, Inc. modules and multichannel rack cabinets. It can also be wall mounted by either M31 or M32 Bracket Assembly (See Figures 3-1, 3-2 and 3-3).
- 3.2 Connect line power to #8 (AC) and #9 (ACC) PWR terminals. Terminal #10 is wired to the case for line power ground (GD). Wire the thermocouple lead wires or the millivolt source to #1 (+) and #2 (-) input terminals. For units with reverse operation, the input lead wires have been reversed internally. For other types of input refer to FIG. 3.4 for input signal wiring. Output signal is obtained from terminals #5 (+) and #6 (-). Refer to FIG. 3.5 for typical wiring of input, output and line power.

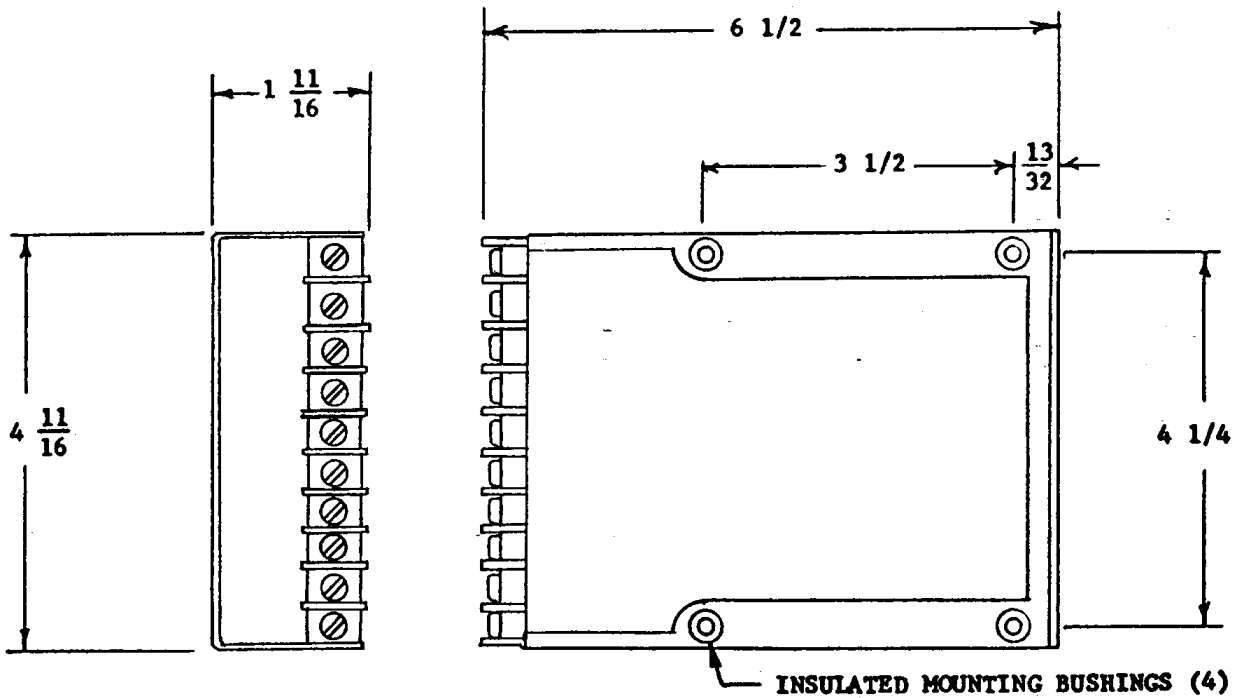

Figure 3-1 - OUTLINE DIMENSIONS - TRANSMITTER CASE

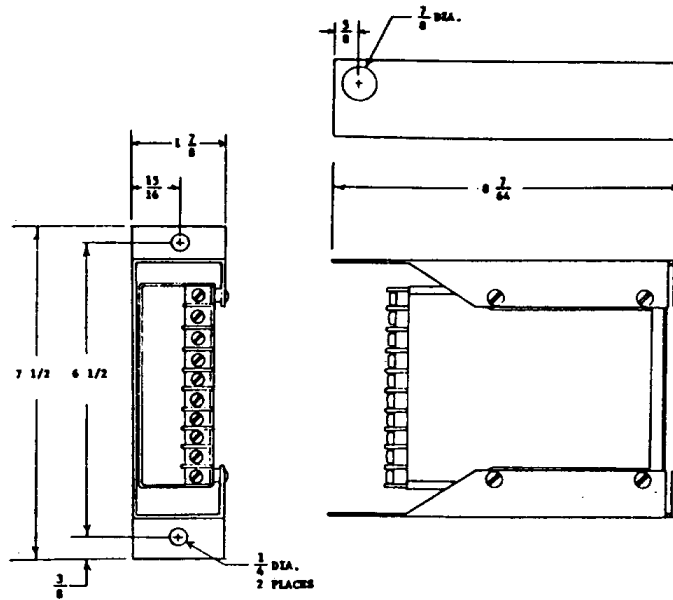

Figure 3-2

OUTLINE DIMENSIONS - TRANSMITTER CASE WITH MOUNTING BRACKET (M31)

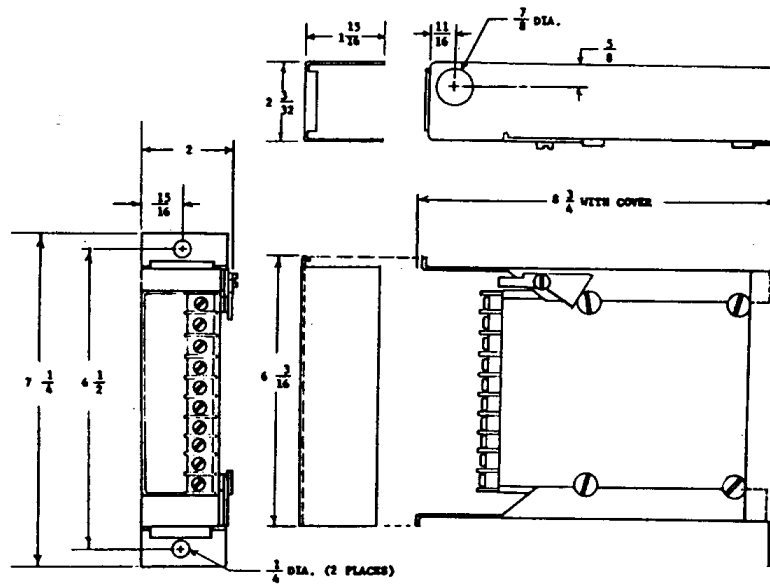

Figure 3-3

OUTLINE DIMENSIONS FOR TRANSMITTER CASE WITH MOUNTING BRACKET, TERMINAL COVER (M32)

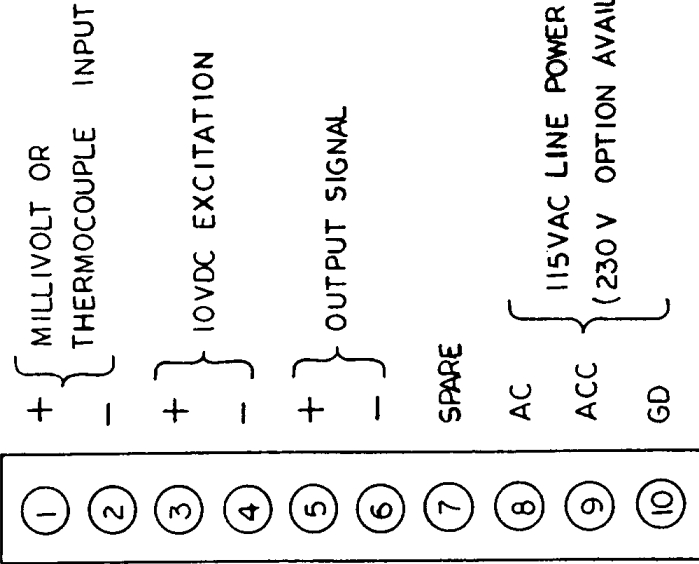
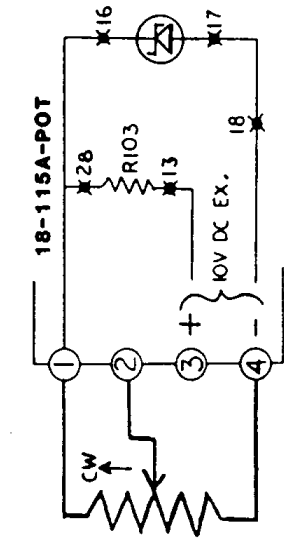

FIGURE 3-5 - FIELD WIRING TERMINALS

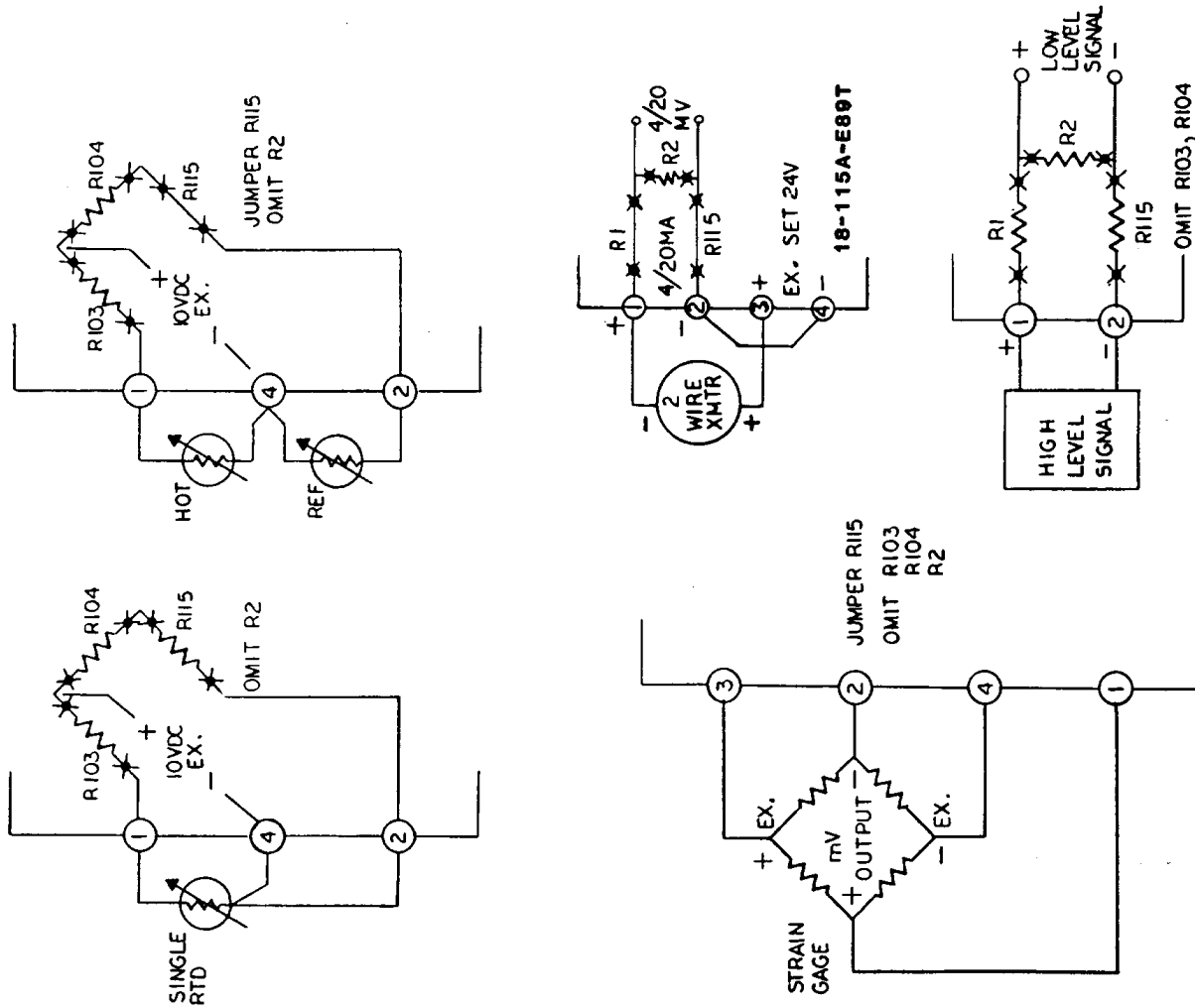

FIGURE 3-4 - EXTERNAL WIRING OF DIFFERENT TYPES OF INPUT SIGNALS

SECTION IV
RECALIBRATION

- 4.1 If a calibration, other than the one originally provided, is desired, changes of several percent can be made quickly by the fine ZERO and SPAN trimmer adjustments. For a major calibration change refer to FIG. 4-1 and 4-3.
- 4.2 T and RT compensate for the non-linearity of the thermocouple in the ambient temperature range (20-50°C). If the thermocouple is linear in that range T or RT may be shorted.
- 4.3 To determine the offset correction required to accommodate the start of output range for an input signal (thermocouple or millivolt), follow the steps outlined in FIG. 4-8.

STEPS	CONDITION REQUIRED	AMPLIFIER INPUT	
		MILLIVOLT	THERMOCOUPLE
1	INPUT SPAN	FIG. 4-2 (Switch S1)	
2	Thermocouple Reference Junction Comp.	OMIT R118	R118, RT, T Connect R11 for: Direct or Reverse FIG. 4-7.
3	Input offset	FIG. 4-2, 4-8.	
4	Linearization (Option - L)	OMIT RL1 thru RL9	RL1 thru RL9
5	Thermocouple Break indication	OMIT R108 if break indication is not desired	R108 (91M) Position switch S3 to upscale or Downscale FIG. 4-2
6	Voltage Output Put two jumpers FIG. 4-9.	R111, R117 FIG. 4-4.	
7	Current Output Put two jumpers FIG. 4-9.	R109, R112, R117 FIG. 4-4.	
8	High Level mv input (Option-E114)	Extend mv offset and span by X10 R10=221Ω 223737-125 R110 parallel with 9.09k 223737-46 R113 parallel with 48.7k 223737-34	

Figure 4-1 - Summary of a major calibration change

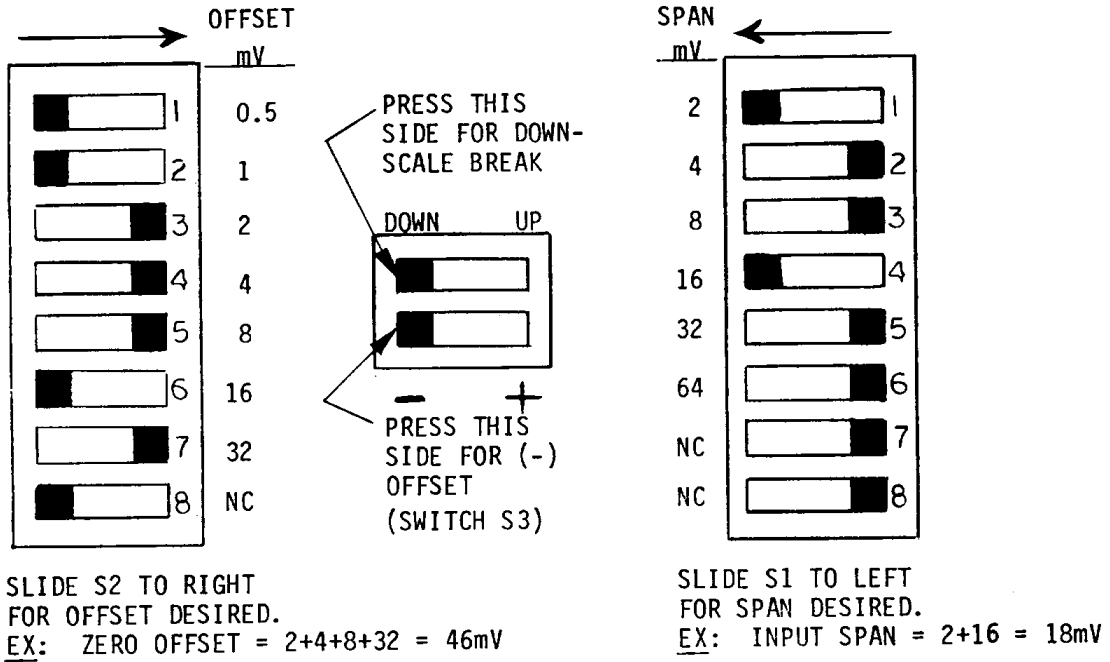

FIGURE 4-2 - EXAMPLES OF ZERO OFFSET AND INPUT SPAN SETTINGS USING THE DIGITAL SWITCHES

CALIB-RATING COMPO-NENTS	TYPE OF INPUT (NON-LINEARIZED)					
	THERMO-COUPLE	SINGLE RTD	DUAL RTD	STRAIN GAGE	VOLTAGE DIVIDER	CURRENT INPUT
R1	249 Ω 223737-54				FIG 4-6	JUMPER
R2	OPEN	OPEN	OPEN	OPEN	FIG 4-6	FIG 4-6
R103	OPEN	FIG 4-5	FIG 4-5	OPEN	OPEN	OPEN
R104	OPEN	FIG 4-5	FIG 4-5	OPEN	OPEN	OPEN
R115	JUMPER	FIG 4-5	JUMPER	JUMPER	FIG 4-6	JUMPER
R118	FIG 4-7	OPEN	OPEN	OPEN	OPEN	OPEN
RT	JUMPER	OPEN	OPEN	OPEN	OPEN	OPEN
R31	20.5K 223737-28					
R32	10K 221734-07					
R20B	JUMPER					
MV INPUT	JUMPER					

FIGURE 4-3 - CALIBRATING COMPONENTS FOR VARIOUS TYPES OF INPUT

CALIB-RATING COMP- ONENTS	TYPE OF OUTPUT							
	0/5 VDC	1/5 VDC	0/10 VDC	1/5 mA	4/20 mA	10/50 mA	4/12 mA	12/20 mA
R117	OPEN	200K 223737-129	OPEN	191K 223737-233			453K 223737-176	30.9K 223737-71
R112	OPEN			5.11K 223737-149			2.49K 514490-2491	
R109	OPEN			453 223737-268	100 223737-41	40.2 223737-52	100 223737-41	
R111	16.5K 223737-99	13.3K 223737-68	33.2K 223737-216	OPEN				
Eo	2 JUMPERS			OPEN				
Io	OPEN			2 JUMPERS				

FIGURE 4-4 - CALIBRATING RESISTORS FOR VOLTAGE OR CURRENT OUTPUTS

	RESISTANCE CHANGE OF A SINGLE OR DUAL RTD OR A VARIABLE RESISTOR				
	1/10 OHMS (1/63 LIMIT)	11/30 OHMS (2/126 LIMIT)	31/70 OHMS (4/252 LIMIT)	71/150 OHMS (10/630 LIMIT)	151/300 OHMS (20/1260 LIMIT)
R103, R104	4.99K 514490-4991	10K 514490-1002	20K 514490-2002	49.9K 514490-4992	100K 514490-1003
R115	START OF THE RANGE				
$\text{MV SPAN} = \frac{10 \text{ VOLTS}}{\text{R103 (K } \Omega) + \text{R115 (K } \Omega)} \times \text{RESISTANCE CHANGE OF RTD (OHMS)}$					

FIGURE 4-5 - CALIBRATING RESISTORS FOR SINGLE OR DUAL RTD OR A VARIABLE RESISTOR

INPUT SIGNAL SPAN	VOLTAGE DIVIDER			
	RATIO	R1	R2	R115
126/500 mV	$\frac{1}{10}$	4.42K 223763-11	1K 223763-10	4.64K 223763-12
0.5/5 V	$\frac{1}{100}$	49.9K 223763-13	1K 223763-10	49.9K 223763-13
5/50 V	$\frac{1}{1000}$	499K 223763-14	1K 223763-10	499K 223763-14
50/500 V	$\frac{1}{10000}$	499K 223763-14	100 223763-09	499K 223763-14

CURRENT IN- PUT SIGNAL I SPAN	R2
0.1/1 mA	100 382842-05
1/10 mA	10 220587-44
10/100 mA	1 220587-28
mV SPAN = (I SPAN) (R2)	

FIGURE 4-6 - CALIBRATING RESISTORS FOR VOLTAGE DIVIDER OR CURRENT INPUT

THERMOCOUPLE TYPE DESIRED	R118, Metal Film 1%, T2	
	VALUE	PART NO.
J(I.C.)	8250 ohms	223737-161
K(C.A.)	10500 ohms	223737-168
T(C.C.)	10500 ohms	223737-168
R(P-PR 13%)	71500 ohms	223737-218
S(P-PR 10%)	71500 ohms	223737-218
E(C.C.)	6980 ohms	223737-62

FIGURE 4-7 - REFERENCE JUNCTION COMPENSATING RESISTOR TABLE

STEPS REQUIRED	INPUT SIGNAL																
	MILLIVOLT	T.C. DIRECT (J)															
1 - Specify input range	5 to 15 mV	0 to 500°F															
2 - Calculate the millivolt input span	+15 - (+5) = 10 mV	+14.108 - (-0.885) = 14.993 mV															
3 - Express the start of input range	+5	-0.885 (Ref 32°F)															
4 - Express start of input range reference to the room temperature (75°F)	+5	-0.885 - (+1.22) = -2.105 (Ref 75°F)															
5 - Enter correction for the T.C. compensation	---	-14.2															
<table border="1"> <thead> <tr> <th>T.C.</th> <th>DIR</th> <th>REV</th> </tr> </thead> <tbody> <tr> <td>J</td> <td>-14.2</td> <td>14.2</td> </tr> <tr> <td>K, T</td> <td>-11.2</td> <td>11.2</td> </tr> <tr> <td>R, S</td> <td>-1.67</td> <td>1.67</td> </tr> <tr> <td>E</td> <td>-16.7</td> <td>16.7</td> </tr> </tbody> </table>			T.C.	DIR	REV	J	-14.2	14.2	K, T	-11.2	11.2	R, S	-1.67	1.67	E	-16.7	16.7
T.C.	DIR	REV															
J	-14.2	14.2															
K, T	-11.2	11.2															
R, S	-1.67	1.67															
E	-16.7	16.7															
6 - Add steps 4 and 5. The total is the offset correction required.	+5	-14.2 + (-2.105) = -16.305															
7 - Set the offset polarity switch S3. Set the offset value switch S2 to the required offset. See FIG. 4-2	(+ offset) Pos. 2, 4 (S2) Pos. right (S3)	(- offset) Pos. 1, 6 (S2) Pos. left (S3)															

FIGURE 4-8 - EXAMPLES OF CALCULATING THE OFFSET CORRECTION

4.4 After all the calibrating resistors are installed, the unit may be calibrated as follows:

- A - Apply minimum input signal and adjust the input zero pot P1 so that the output of the precision operational amplifier U1 reads 0 volts.
- B- Apply 10% input signal and adjust the input span pot P2 so that the output of the operational U1 reads 1 volt. In case where the input signal is not to be linearized, apply maximum input signal and adjust the span pot P2 for 10V output of U1.
- C - Repeat steps A and B until the output of U1 reads 0 to 1 volt for minimum to 10% input signal.
- D - Apply maximum input signal and adjust the linearizing pot P3 so that the output of the linearizing circuit (U2A) reads - 10VDC.
- E - Apply minimum input signal and adjust the output zero pot p% so that minimum output signal is obtained.
- F - Apply maximum input signal and adjust the output span pot P4 so that maximum output signal is obtained.
- G - Repeat steps E and F until for minimum to maximum input signal, minimum to maximum output signal is obtained.

4.5 In case of an RTD or strain gage input, before starting the calibration procedure, adjust the excitation pot P6 so that the voltage across terminals #3 and #4 reads 10V.

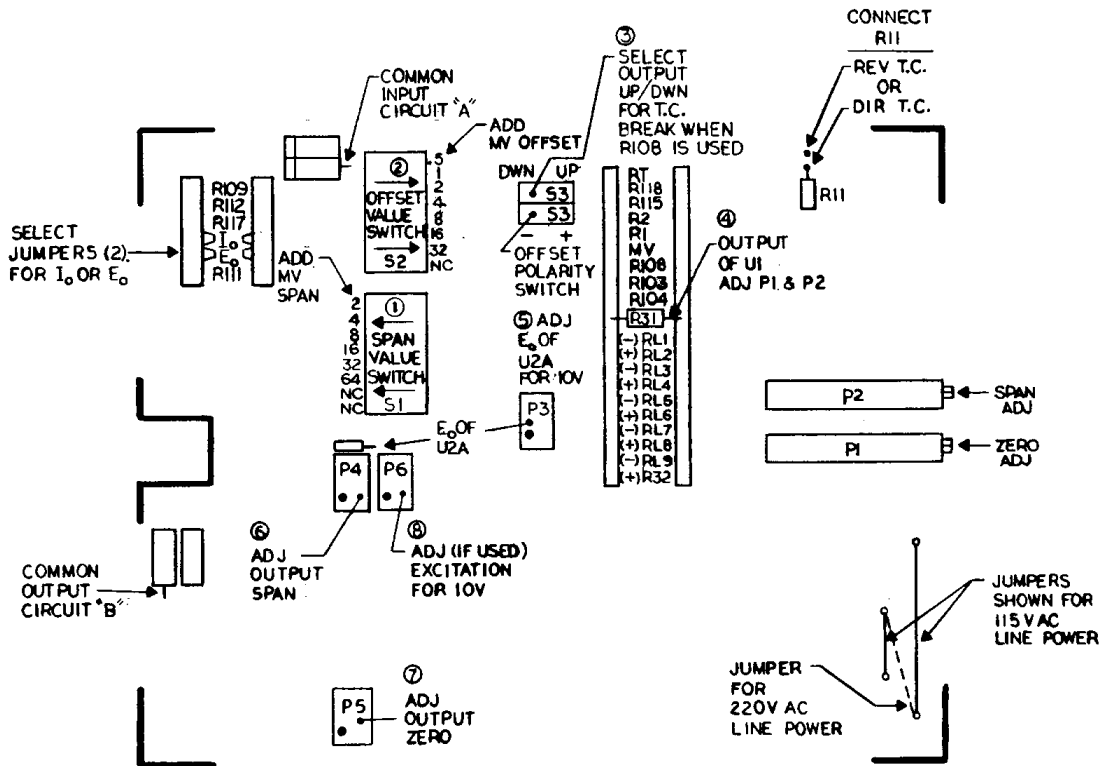

FIGURE 4-9 - LOCATION OF CALIBRATION COMPONENTS AND ADJUSTMENTS

4.4 After all the calibrating resistors are installed, the unit may be calibrated as follows:

- A - Apply minimum input signal and adjust the input zero pot P1 so that the output of the precision operational amplifier U1 reads 0 volts.
- B- Apply 10% input signal and adjust the input span pot P2 so that the output of the operational U1 reads 1 volt. In case where the input signal is not to be linearized, apply maximum input signal and adjust the span pot P2 for 10V output of U1.
- C - Repeat steps A and B until the output of U1 reads 0 to 1 volt for minimum to 10% input signal.
- D - Apply maximum input signal and adjust the linearizing pot P3 so that the output of the linearizing circuit (U2A) reads - 10VDC.
- E - Apply minimum input signal and adjust the output zero pot p% so that minimum output signal is obtained.
- F - Apply maximum input signal and adjust the output span pot P4 so that maximum output signal is obtained.
- G - Repeat steps E and F until for minimum to maximum input signal, minimum to maximum output signal is obtained.

4.5 In case of an RTD or strain gage input, before starting the calibration procedure, adjust the excitation pot P6 so that the voltage across terminals #3 and #4 reads 10V.

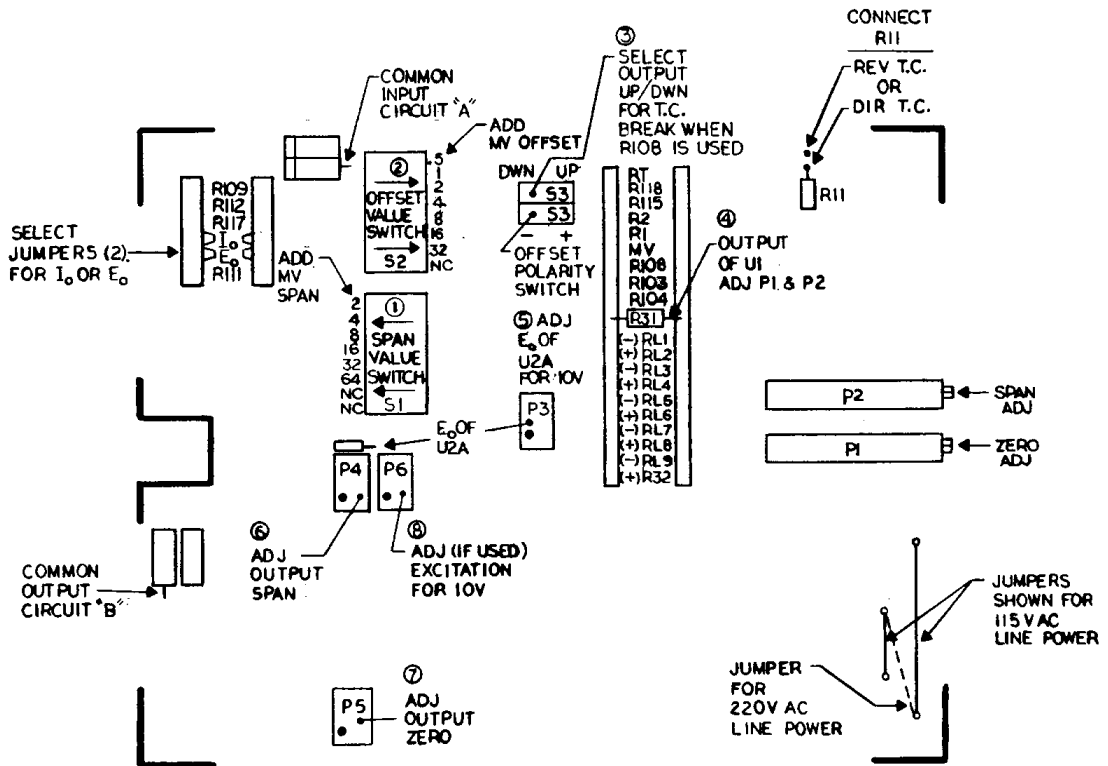
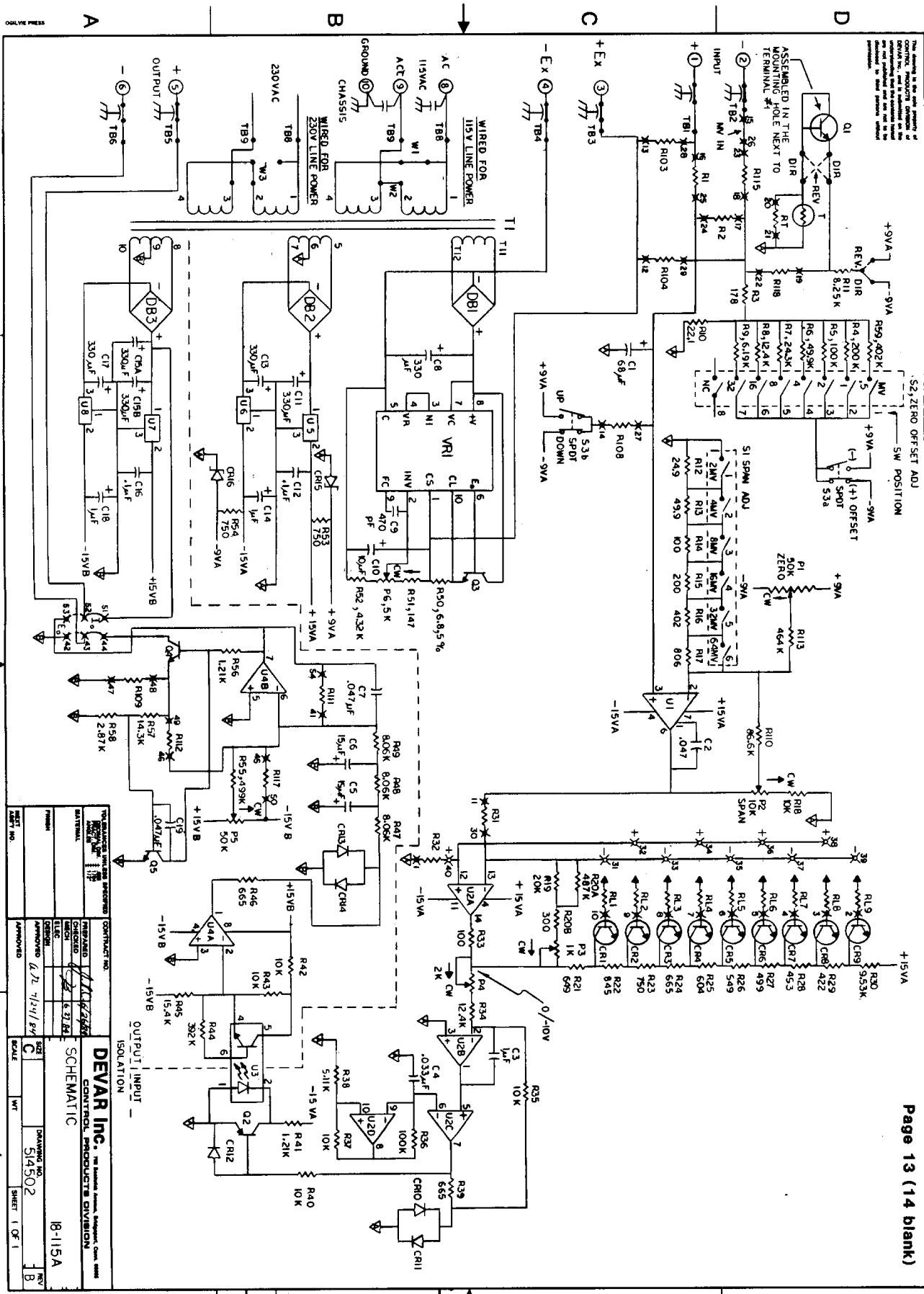

FIGURE 4-9 - LOCATION OF CALIBRATION COMPONENTS AND ADJUSTMENTS

The drawing is the sole property of CONTROL PRODUCTS and is not to be reproduced, stored in a retrieval system, or transmitted in any form or by any means, electronic, mechanical, photocopying, recording, or by any information storage and retrieval system, without the prior written permission of CONTROL PRODUCTS.



DEVAR Inc. CONTROL PRODUCTS DIVISION 18-115A	
CONTRACT NO. 514502	DRAWING NO. 514502
CHECKED BY DATE	APPROVED BY DATE
DESIGNED BY DATE	CHECKED BY DATE
DRAWN BY DATE	APPROVED BY DATE
SCALE WT	SHEET 1 OF 1

FIGURE 5-1

SECTION VIPARTS LIST

6.1 Parts relating to calibration are identified in Recalibration Section IV. To order spare or replacement parts, contact your local Devar, Inc., Control Products Division representative. Whenever possible, specify items by description and part number.

<u>6.2 Resistor, 1% Metal Film</u>			<u>Parts No.</u>
R3	178 ohms	T13	514490-1780
R4	200K ohms	T13	514490-2003
R5	100K ohms	T13	514490-1003
R6	49.9K ohms	T13	514490-4992
R7	24.3K ohms	T13	514490-2432
R8	12.4K ohms	T13	514490-1242
R9	6.19K ohms	T13	514490-6191
R10	22.1 ohms	T13	514490-0221
R11	8.25K ohms	T1	514458-8251
R12	24.9 ohms	T13	514490-0249
R13	49.9 ohms	T13	514490-0499
R14	100 ohms	T13	514490-1000
R15	200 ohms	T13	514490-2000
R16	402 ohms	T13	514490-4020
R17	806 ohms	T13	514490-8060
R18	10K ohms	T13	514490-1002
R19	20K ohms	T13	514490-2002
R21	649 ohms	T1	514458-6490
R22	845 ohms	T1	514458-8450
R23, 53, 54	750 ohms	T1	514458-7500
R24, 39, 46	665 ohms	T1	514458-6650
R25	604 ohms	T1	514458-6040
R26	549 ohms	T1	514458-5490
R27	499 ohms	T1	514458-4990
R28	453 ohms	T1	514458-4530
R29	422 ohms	T1	514458-4220
R30	9.53K ohms	T1	514458-9531
R33	100 ohms	T1	514458-1000
R34	12.4K ohms	T2	223737-193
R35, 37	10K ohms	T2	221734-07
R36	100K ohms	T2	223737-135
R38	5.11K ohms	T2	223737-149
R40, 42, 43	10K ohms	T1	514458-1002
R41, 56	1.21K ohms	T1	514458-1211
R44	392K ohms	T1	514458-3923
R45	15.4K ohms	T1	514458-1542
R47, 48, 49	8.06K ohms	T2	223737-50
R50	6.8 ohms	5%	222087-69
R51	147 ohms	T2	223737-18
R52	4.32K ohms	T2	223737-26
R55	499K ohms	T2	223737-133
R57	14.3K ohms	T2	223737-196
R58	2.87K ohms	T1	221734-54
R59	402K ohms	T2	223737-61
R110	86.6K ohms	T13	514490-8662
R113	464K ohms	T2	223737-254

6.3 PotentiometersParts No.

P1	50K ohms, #78P	223865-10
P2	10K ohms, #78P	223865-05
P3	1K ohms, #68W	381356-07
P4,	2K ohms, #68W	381356-08
P6	5K ohms, #68W	381356-09

6.4 Capacitors

C1	68uF, 6WV	Tantalum	380767-02
C2, 7, 19	.047uF, 50WV	Ceramic	382437-01
C3	1uF, 100WV	Mylar	221282-07
C4	.033uF, 100WV	Mylar	220696-06
C5, 6	15uF, 20WV	Tantalum	221674-02
C8, 11, 13, 15A&B, 17	330uF, 50WV	Electrolytic	514491-01
C9	470pF, 50WV	Ceramic	221733-06
C10	10uF, 20WV	Tantalum	380767-01
C12, 16	0.1uF, 100WV	Ceramic	382437-02
C14, 18	1.0uF, 35WV	Tantalum	380767-04

6.5 Semiconductors

CR1 thru 9	Transistors 2N5232A	380668-02
CR10, 11	Zeners, Matched	382138-02
CR13, 14	Zeners, Matched	382138-02
CR12	Diode 1N4153	222095-01
CR15, 16	Zener 1N937B	221799-01
Q1	Transistor, Selected	223426-01
Q2	Transistor 2N3702	222957-01
Q3	Transistor 2N5191	380934-01
Q4	Transistor MPSU03	380511-01
Q5	Transistor 2N5232A	380668-02
DB1, 2, 3	Diode Bridge	380766-02

6.6 Integrated Circuits

U1	Operational Amplifier, Precision	513297-01
U2	Quad Operational Amplifier	382541-02
U3	Opto-Isolator 4N25	381849-01
U4	Dual Operational Amplifier	382541-01
U5, 7	Positive Voltage Regulator	381584-02
U6, 8	Negative Voltage Regulator	514495-01
VRI	Voltage Regulator 723C	381370-01

6.7 Transformer

T1	Power Transformer	514501-01
----	-------------------	-----------

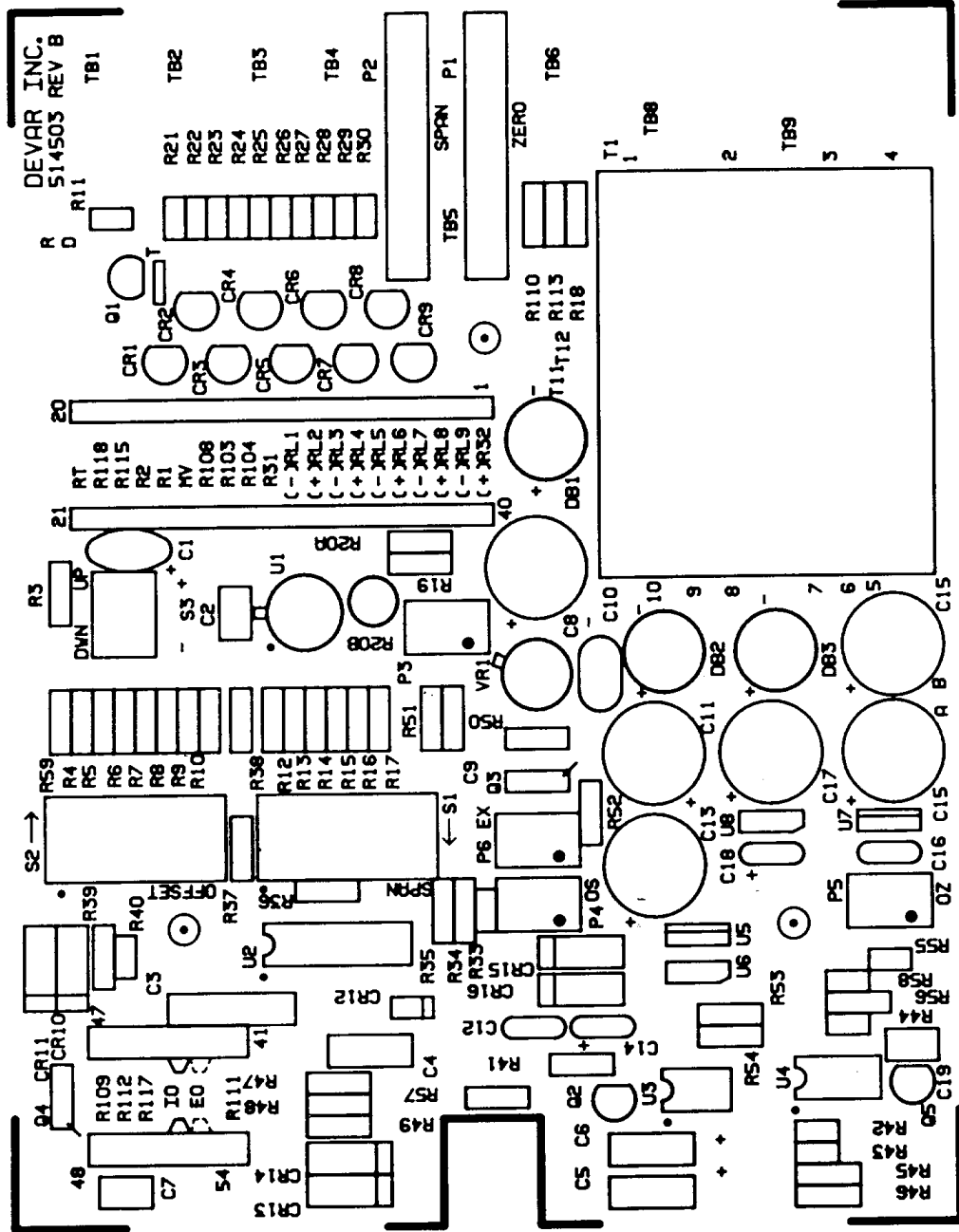

FIGURE 6-1 - PARTS LOCATIONS, 18-115A ISOLATED SENSOR TRANSMITTER