

DEVAR Inc.



Model 3020 User Manual

Table of Contents

Introduction	ii	1.7.1	Relay Lock-Out Setting	14
Front Panel Features	iii	1.7.2	Limit Settings	14
Manual Guidelines	vi	1.7.3	Relay Settings	15
1.0 Basic Use - Configuration	1	1.8	Horn Action Settings	15
1.1 Peak and Valley	1	1.9	Analog Retransmission	16
1.2 Enter Access Code	2	1.10	Changing the Access Code	17
1.3 Select Input Type	3	2.0	Advanced Features	18
1.4 Setup Display	4	2.1	DIP Switch Settings	18
1.4.1 Set the Decimal Point	4	2.2	Analog Retransmission Option	19
1.4.2 Select the Process Label	5	2.2.1	Card Configuration	19
1.4.3 Select the Input Output Curve	6	2.2.2	Set Output Values	20
1.4.4 Define Maximum Range	6	2.2.3	Adjust Output Signal	21
1.4.5 Define Minimum Range	7	2.3	Non Standard Inputs	22
1.5 Adjust Offset	7	2.31	Square Root Response	22
1.6 Setting Control or Alarms Points	8	2.32	Custom Input Curve	23
1.6.1 Trip Settings	9	3.0	Frequently Asked Questions	25
1.6.2 Reset Settings	9	4.0	Error Codes/Troubleshooting	27
1.6.3 Trip Delay Settings	10	5.0	Specifications	28
1.6.4 Reset Delay Settings	10	A-1	Field Wiring	I
1.6.5 Horn Settings	10	A-2	Menu Flowchart	III
1.6.6 Latch Settings	11	A-3	Typical Configuration Example	IV
1.6.7 Flash Screen Settings	11	A-4	Typical Configuration Worksheet	V
1.6.8 Fail Safe Polarity Settings	12	A-5	Custom Curve Configuration Example	VI
1.6.9 Alternation Settings	13	A-6	Custom Configuration Worksheet	VII
1.6.10 Alarm or Pump Settings	13		Warranty Information	VIII
1.7 Detecting Sensor Failure	14			

Introduction

Welcome to the Model 3020 user manual. This Pump Controller with alarm capability is accurate, easy to configure, and easy to operate. In this manual you will find an overview on how to configure your controller.

The Model 3020 includes the following features:

- Six character alphanumeric display
- Scrolling multi-word configuration prompts for clarity
- Four control channels with LED indication
- Control channel menu prompts can be set for alarms or pumps
- Control channels can be independently configured for different trip and reset points
- Controls can have independently configured trip and reset delay times
- Two, three, or all four controls can be set to alternate
- Alarms can be independently configured to latch
- Alarms can be independently configured to activate a horn
- Four separate horn actions
- A security code can be set to prevent unauthorized use
- UL listed

Front Panel Features

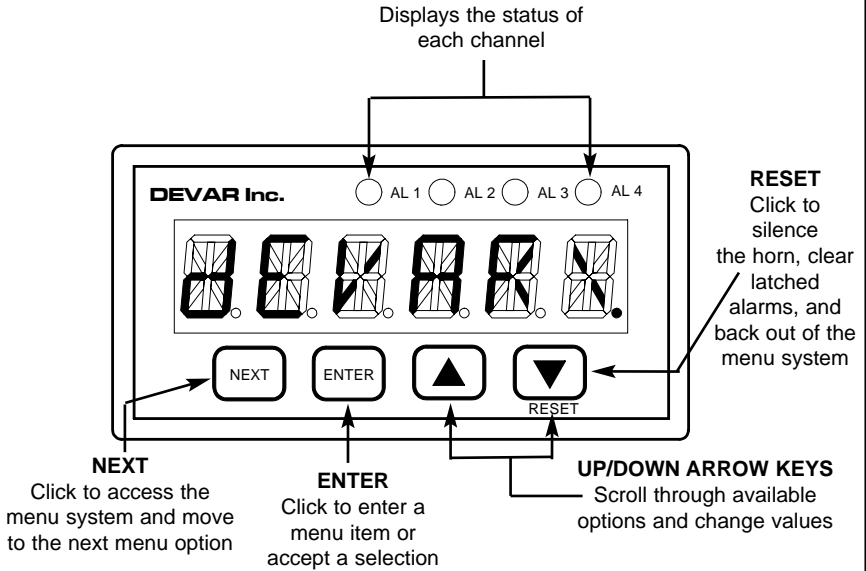

FIGURE 1 Model 3020 Front Panel

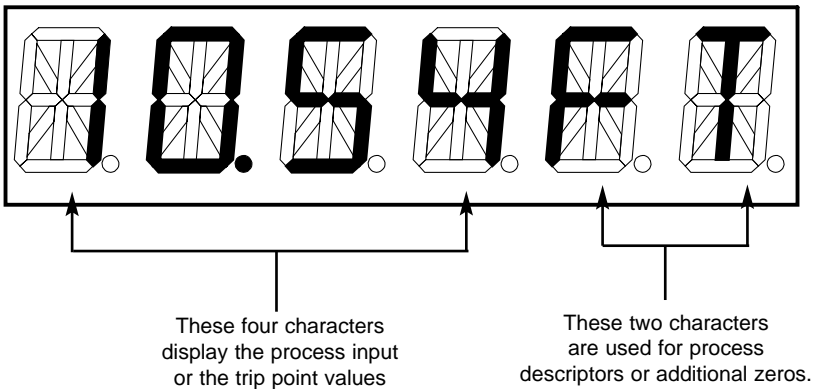

FIGURE 2 Model 3020 Front Panel - Characters

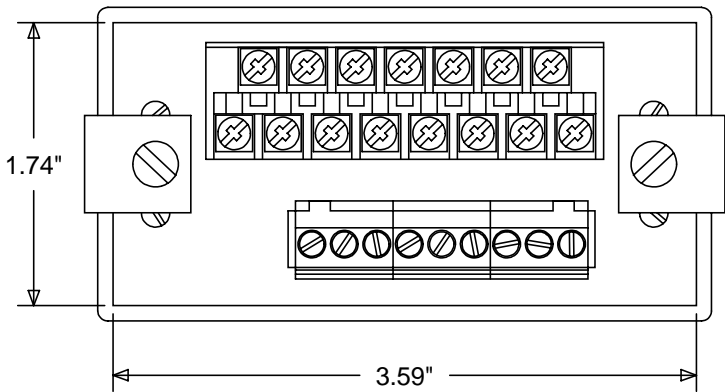
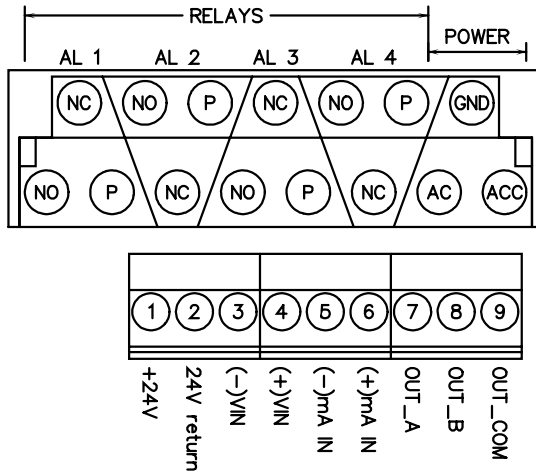

FIGURE 3 Model 3020 Back Panel



POWER: 90/140 VAC 50/60 Hz OR 130/190 VDC
 ACC = AC NEUTRAL OR DC RETURN
 AC = AC HOT OR \pm DC (FUSED LINE)
 FUSE: 1/8A 250V LITTELFUSE SERIES 230.
 INSTALLED ON PC BOARD, NOT FIELD REPLACABLE

OPTION	OUT_COM	OUT_B	OUT_A
Vout	COMMON	Vout	NC
Isink	mA return	+mA in	NC
Isource	NC	mA return	+mA out
RS-232	COMMON	Tx	Rx
RS-485	COMMON	B	A

NOTE:

Isink: EXTERNAL SUPPLY DRIVES LOOP
 Isource: INTERNAL SUPPLY DRIVES LOOP

FIGURE 4 Model 3020 Back Panel - Connectors

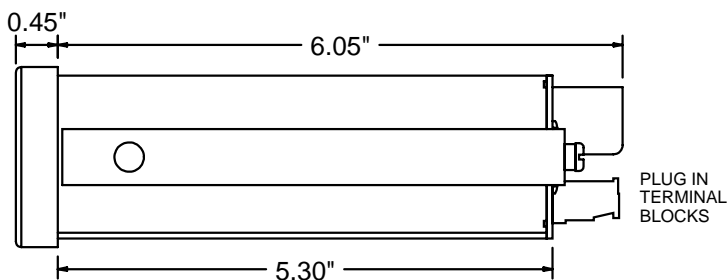
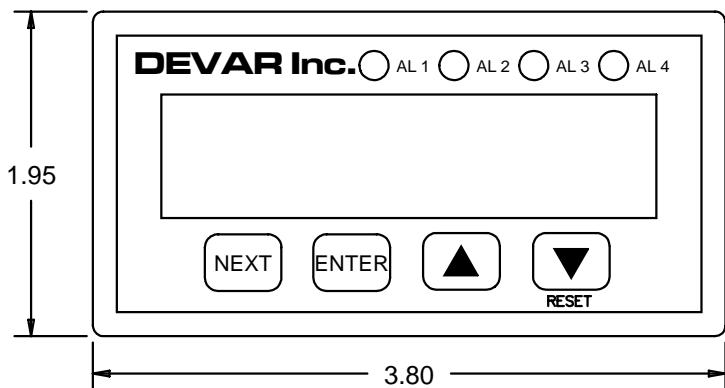





PANEL CUTOUT	
92 ^{+0.8} _{-0.5}	X 45 ^{+0.8} _{-0.5} mm
3.622 ^{+0.032} _{-0.019}	X 1.772 ^{+0.032} _{-0.019} INCHES

FIGURE 5 Model 3020 General Dimensions

Manual Guidelines

Throughout this manual you will see words that represent the front panel push buttons and the menu prompts that appear on the display. TABLE 1 shows the graphics and text used to represent the buttons. See Appendix 2 - Menu Flowchart for a list of all the menu prompts displayed by the controller.

TABLE 1 Input Type Options

Button	Representation
	NEXT
	ENTER
	UP ARROW or DOWN ARROW
	RESET

Section 1

1.0 Basic Use - Configuration

This section introduces you to the basic use of the Model 3020. Before you begin to configure your controller, fill out the Pre-configuration Worksheet with the settings you will be using (see Appendix 4).

NOTE:

For ease of configuration, we recommend that you apply power to the controller and configure it at your desk prior to installation.

TIP:

See Appendix 2 for a flowchart showing the menu system and prompts.

When power is first applied to the controller, the screen displays the model number, build date, and other basic configuration parameters. You can temporarily pause the startup message by pressing and holding any of the buttons. After the startup message is displayed, the 3020 becomes operational and the process input is displayed. The operating unit continuously scans the front panel switches for user input.

⇒ To enter into the menu system, press NEXT. The Peak and Valley menu item appears.

1.1 *Peak and Valley*

PEAK AND VALLEY is the first menu item you will see. This menu allows you to view and/or clear the largest and smallest process values detected.

1. Press ENTER. The View Peak prompt appears.
2. Press ENTER again to view the current Peak value.
3. After viewing the value, press NEXT. The Clear Peak prompt appears.

4. If you want to clear the Peak value, press ENTER. STORED is displayed confirming your selection. If you do not want to clear the Peak value, press NEXT.
5. The View Valley prompt appears.
6. Press ENTER to view the current Valley value.
7. After viewing the value, press NEXT. The Clear Valley prompt appears.
8. If you want to clear the Valley value, press ENTER. STORED is displayed confirming your selection. If you do not want to clear the Valley value, press NEXT to return to view Peak and Valley.
9. Press NEXT again. The Enter Access Code prompt appears.

NOTE:

When navigating through the menu system:

- Press ENTER to enter a menu item.
- Press NEXT to move to the next menu item.
- Press RESET to exit a menu item.

1.2 Enter Access Code

The **ENTER ACCESS CODE** menu item allows you to enter the configuration menu and prevents unauthorized modification of the meter configuration.

NOTE:

This menu item only appears if the DIP switch SW2 pole 4 is in the ON position. See Section 2.1, DIP switch settings.

1. Press ENTER. The default Access Code "000000" appears.
2. Press the UP ARROW or DOWN ARROW to increase or decrease the value of the flashing digit.

3. Press NEXT to move to the next digit.
4. After entering an Access Code, press ENTER. OKAY appears if the code is correct; DENIED appears if incorrect.

1.3 Select Input Type

The **SELECT INPUT TYPE** menu item allows you to select the input you want to apply to the controller.

NOTE:

You can skip this section if the input is 4/20mA. Since this is the factory default setting, no action is necessary.

1. Press ENTER. The Select Input Type prompt appears.
2. Press the UP ARROW or DOWN ARROW to view the options. See TABLE 2 for the available options.

TABLE 2 Input Type Options

-10/+10V
0/10V
0/5V
1/5V
0/20mA
4/20mA
0/1V

3. After selecting the Input Type, press ENTER. STORED is displayed confirming your selection.
4. Press NEXT. The Setup Display menu appears.

1.4 Setup Display

The **SETUP dISPLAY** menu item allows you to configure the Model 3020 to display the level in your tank. This is where you set the decimal point, select the process label, and define the input/output curve.

NOTE:

The Model 3020 should be configured to match the output range of your transmitter.

⇒ Press ENTER. The SET dP prompt appears.

1.4.1 Set the Decimal Point

The **SET dP** prompt allows you to place the decimal point.

1. Press ENTER. The current setting appears as a flashing digit with the decimal point to the right of the digit (factory setting: 012.345).
2. Press the UP ARROW or DOWN ARROW to move the decimal point to the desired position.
3. After positioning the decimal point, press ENTER. STORED is displayed confirming your selection.

NOTE:

Only the first four digits, '0123,' will actively display the input regardless of where the decimal point is placed. When either '01234.5' or '012345.' is selected as a decimal point position, dummy zeros will occupy the '45' positions that would otherwise be used to display the label.

1.4.2 Select the Process Label

The **PICK LABEL** prompt allows you to set the two character process label.

1. Press ENTER. The current setting appears with a flashing character.

NOTE:

In this example, XX is the current setting. The flashing character is the character you can edit. A blank space is also a valid character.

2. Press the UP ARROW or DOWN ARROW to find the desired character.

NOTE:

Characters include numbers 0 through 9, upper and lower case letters, and other characters as @, #, etc.

3. To edit the next character, press NEXT.
4. Press the UP ARROW or DOWN ARROW to find the desired character.
5. Press ENTER to save the setting. STOREd is displayed confirming your selection.

1.4.3 Select the Input Output Curve

The **INPUT OUTPUT CURVE** prompt allows you to configure the display for a linear or nonlinear input curve. This prompt defines how the unit reacts to the input signal.

1. Press ENTER. The current setting appears.

NOTE:

The factory default setting is LINEAR INPUT. For more information about other settings, see Section 2.3. Sections 1.4.4 and 1.4.5 are only valid for LINEAR INPUT.

2. Press the UP ARROW or DOWN ARROW to change the current setting.
3. Press ENTER to save the setting. STOREd is displayed confirming your selection.

1.4.4 Define Maximum Range

The **dEFINE MAX. RANGE** prompt allows you to set the process value to be displayed at the maximum input signal.

1. Press ENTER. The current setting appears.
2. Press the UP ARROW or DOWN ARROW to increase or decrease the value of the flashing digit.
3. Press NEXT to move to the next digit.
4. After changing all the digits, press ENTER to save the setting. STOREd is displayed confirming your selection.

1.4.5 Define Minimum Range

The **DEFINE MIN. RANGE** prompt allows you to set the process value to be displayed at the minimum input signal.

1. Press ENTER. The current setting appears.
2. Press the UP ARROW or DOWN ARROW to increase or decrease the value of the flashing digit.
3. Press NEXT to move to the next digit.
4. After changing all the digits, press ENTER to save the setting. STOREd is displayed confirming your selection.

1.5 Adjust Offset

The **AdJUST OFFSET** menu item allows you to add or subtract a value from the display to accommodate the location of the transmitter. For example, if the transmitter is on the bottom of the tank, the setting is zero; if the transmitter is 1 ft. off the bottom, the setting is one.

1. Press ENTER. The current setting appears.
2. Press the UP ARROW or DOWN ARROW to increase or decrease the value of the flashing digit.
3. Press NEXT to move to the next digit.
4. After changing all the digits, press ENTER to save the setting. STOREd is displayed confirming your selection.
5. Press NEXT.

1.6 Setting Control or Alarms Points

The Model 3020 has four control or alarm channels. LEDs on the front panel indicate which channel(s) has been tripped. See **FIGURE 6** for an example of channels tripped on two pumps.

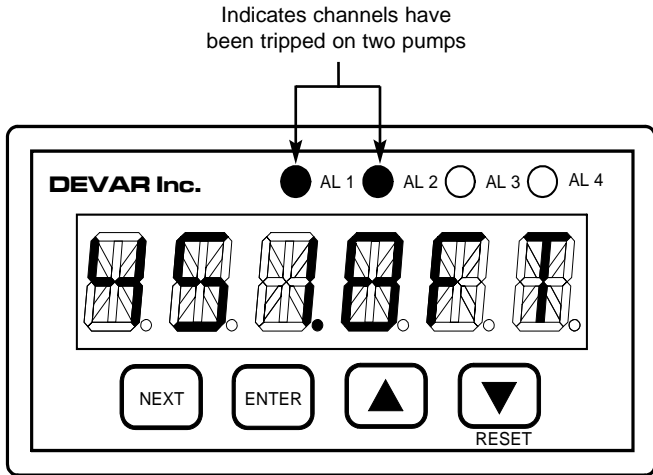

FIGURE 6 Channel indicators on the front panel

1. The PUMP 1 or ALARM 1 prompt appears. Press ENTER to configure the channel.
2. Or press NEXT to move to the next channel.

NOTE:

Each of the channels may be set to display "PUMP" or "ALARM." Each setting has the channel number as part of the prompt.

1.6.1 Trip Settings

The **TRIP** prompt allows you to set the point at which the pump turns on or the alarm trips.

1. The TRIP 1 prompt appears.
2. Press ENTER. The current setting appears.
3. Press the UP ARROW or DOWN ARROW to increase or decrease the value of the flashing digit.
4. Press NEXT to move to the next digit.
5. After changing all the digits, press ENTER to save the setting. STORED is displayed confirming your selection.

1.6.2 Reset Settings

The **RESET** prompt allows you to set the point at which the pump turns off or the alarm resets.

NOTES:

1. If you set the TRIP point to a higher value than the RESET point, the alarm is configured as a high alarm. If you set the trip point to a lower value than the RESET point, it is configured as a low alarm.
2. Setting the TRIP and RESET points to the same value disables the channel and de-energizes the relay.

1. The RESET 1 prompt appears.
2. Press ENTER. The current setting appears.
3. Press the UP ARROW or DOWN ARROW to increase or decrease the value of the flashing digit.
4. Press NEXT to move to the next digit.
5. After changing all the digits, press ENTER to save the setting. STORED is displayed confirming your selection.

1.6.3 Trip Delay Settings

The **TRIP dELAY** prompt controls the length of time the process must remain beyond the **TRIP** value before activating the alarm/control. Delay times can be set from 0 to 240 seconds.

1. The **TRIP dELAY 1** prompt appears. Press **ENTER**. The current setting appears.
2. Press the **UP ARROW** or **DOWN ARROW** to increase or decrease the value of the flashing digit.
3. Press **NEXT** to move to the next digit.
4. After changing all the digits, press **ENTER** to save the setting. **STOREd** is displayed confirming your selection.

1.6.4 Reset Delay Settings

The **RESET dELAY** prompt controls the length of time the process must remain beyond the **RESET** value before de-activating the alarm/control. Delay times can be set from 0 to 240 seconds.

1. The **RESET dELAY 1** prompt appears. Press **ENTER**. The current setting appears.
2. Press the **UP ARROW** or **DOWN ARROW** to increase or decrease the value of the flashing digit.
3. Press **NEXT** to move to the next digit.
4. After changing all the digits, press **ENTER** to save the setting. **STOREd** is displayed confirming your selection.

1.6.5 Horn Settings

The **HORN** prompt allows you to set each alarm to activate a horn.

1. The **HORN 1** prompt appears. Press **ENTER**. The current setting appears.
2. Press the **UP ARROW** or **DOWN ARROW** to select **SILENT** or **SOUND**.
3. Press **ENTER** to save the setting. **STOREd** is displayed confirming your selection.

1.6.6 Latch Settings

The **LATCH** prompt allows you to configure a channel to remain latched in the alarm state even after the input has returned to a non-alarm condition.

1. The **LATCH 1** prompt appears. Press **ENTER**. The current setting appears.
2. Press the **UP ARROW** or **DOWN ARROW** to select **dO NOT LATCH** or **dOES LATCH**.
3. Press **ENTER** to save the setting. **STOREd** is displayed confirming your selection.

NOTE:

A latched alarm can be cleared by pressing the **RESET** button on the front panel (see **FIGURE 1**)

1.6.7 Flash Screen Settings

The **FLASH SCREEN** prompt allows you to configure the controller to indicate a tripped condition by flashing the display.

1. The **FLASH SCREEN** prompt appears. Press **ENTER**. The current setting appears.
2. Press the **UP ARROW** or **DOWN ARROW** to select **ON ALARM** or **NEVER**.
3. Press **ENTER** to save the setting. **STOREd** is displayed confirming your selection.

1.6.8 Fail Safe Polarity Settings

The **FAIL SAFE POLARITY** prompt allows you to select whether the output relay will be energized, (N.O. contact closed) or de-energized, (N.C. contact closed) when in the tripped state.

NOTE:

For FAIL TRIPPED, the channel will trip on loss of power.
For FAIL RESET, the channel will reset on loss of power.

1. The FAIL SAFE POLARITY 1 prompt appears. Press ENTER. The current setting appears.
2. Press the UP ARROW or DOWN ARROW to select FAIL RESET or FAIL TRIPPED.
3. Press ENTER to save the setting. STORED is displayed confirming your selection.

TIP:

After installing the controller, perform a safety test by removing power to the 3020. The relays are wired correctly if the controlled functions are all in their failsafe conditions, (e.g., the pumps are off and the alarms are on).

1.6.9 Alternation Settings

The **ALTERNATION** prompt allows you to set any of two, three or four channels to alternate. Each channel is configured separately. Each time the first trip point is reached, one of the alternating channels will turn a pump on. Another pump will turn on for each additional trip point that is reached.

NOTE:

Alternating channels must be set so that they all trip on a high going signal or all trip on a low going signal. The trip points should all be set to different values.

1. The **ALTERNATION** prompt appears. Press **ENTER**. The current setting appears.
2. Press the **UP ARROW** or **DOWN ARROW** to select **dO NOT TOGGLE** or **dOES TOGGLE**.
3. Press **ENTER** to save the setting. **STOREd** is displayed confirming your selection.

1.6.10 Alarm or Pump Settings

The **ALARM** or **PUMP** prompt allows you to label the channel that you are configuring as an alarm or as a pump control.

1. The **ALARM OR PUMP** prompt appears. Press **ENTER**. The current setting appears.
2. Press the **UP ARROW** or **DOWN ARROW** to select **PUMP** or **ALARM**.
3. Press **ENTER** to save the setting. **STOREd** is displayed confirming your selection.

NOTE:

To configure channels 2 through 4, repeat the steps in the Alarm Settings Sections 1.6.1 to 1.6.10.

1.7 **Detecting Sensor Failure**

The **DETECT SENSOR FAILUR** menu item gives you the option to control the relay outputs if the sensor fails.

1. The **DETECT SENSOR FAILUR** prompt appears.
2. Press **ENTER** to enter the **RELAY LOCK-OUT** menu.
3. Or press **NEXT** to move to **HORN ACTION**.

1.7.1 **Relay Lock-Out Setting**

The **RELAY LOCK-OUT** prompt allows you to define the input values that indicate a faulty sensor and the state each relay will enter if the sensor fails.

1. The **RELAY LOCK-OUT** prompt appears. Press **ENTER**. The current setting appears.
2. Press the **UP ARROW** or **DOWN ARROW** to select **ENABLE** or **IGNORE**.
3. Press **ENTER** to save the setting. **STOREd** is displayed confirming your selection.

1.7.2 **Limit Settings**

The **LIMIT1** and **LIMIT2** prompts allow you to specify the maximum and minimum input values that define a valid signal range.

1. The **LIMIT1** prompt appears. Press **ENTER**. The current setting appears.
2. Press the **UP ARROW** or **DOWN ARROW** to increase or decrease the value of the flashing digit.
3. Press **NEXT** to move to the next digit.
4. After changing all the digits, press **ENTER** to save the setting. **STOREd** is displayed confirming your selection.
5. Press **NEXT**. Repeat the process for **LIMIT 2**.

NOTE:

LIMIT 1 and LIMIT 2 define the limits of a valid input range. Limits are specified in terms of the displayed process value not the electrical signal, e.g. 11.5 ft not 20 mA. It does not matter which LIMIT is used to represent the top or the bottom of the range.

1.7.3 Relay Settings

The **RELAY1** through **RELAY4** prompts allow you to specify the state each relay will be placed in after an input failure is detected.

1. The RELAY1 prompt appears. Press ENTER. The current setting appears.
2. Press the UP ARROW or DOWN ARROW to select TRIPPd or RESET.
3. Press ENTER to save the setting. STOREd is displayed confirming your selection.
4. Press NEXT. Repeat the process for the next relay.

1.8 Horn Action Settings

The horn will be enabled if DIP switch SW2 pole 3 is set to ON (see section 2.1). The **HORN ACTION** menu item allows you to control how the horn reacts (i.e., what triggers it to sound and what causes it to go silent). Any, none, or all of the alarms can cause the horn to sound.

NOTE:

The RESET button on the front panel (see **FIGURE 1**) is used to silence the horn. If the alarm is latched, pressing RESET a second time will unlatch the alarm.

1. The HORN ACTION prompt appears. Press ENTER. The current setting appears.
2. Press the UP ARROW or DOWN ARROW to select SOUND WITH ALARM, SOUND UNTIL RESET, LATCH GOING ACTIVE or LATCH WITH CHANGE (see table 3).
3. Press ENTER to save the setting. STORED is displayed confirming your selection.

TABLE 3 Horn Actions

Setting	Description
SOUND WITH ALARM	Causes the horn to sound when an alarm is tripped and to be silent when all alarms are clear. If any alarm is configured to LATCH, you must press RESET to unlatch alarms that are clear.
SOUND UNTIL RESET	The horn sounds when an alarm is tripped and is silent when either all alarms are clear or the RESET is pressed. If any alarm is configured to LATCH, you must press RESET again to unlatch alarms that are clear.
LATCH GOING ACTIVE	The horn sounds and stays on after an alarm is tripped. You can only silence the horn by pressing the RESET button. If any alarm is configured to LATCH, you must press RESET again to unlatch alarms that are clear.
LATCH WITH CHANGE	The horn sounds and stays on after an alarm either trips or clears. You can only silence the horn by pressing the RESET button. If any alarm is configured to LATCH, you must press RESET again to unlatch alarms that are clear.

1.9 Analog Retransmission

The ANALOG REXMIT menu item allows you to configure the analog output option. This prompt only appears if the Analog Retransmission Option has been provided. For a complete description of the option, see *Section 2.2*.

1.10 Changing the Access Code

The **CHANGE ACCESS CODE** menu item allows you to define a new access code.

1. The **CHANGE ACCESS CODE** prompt appears. Press **ENTER**. The current Access Code appears.
2. Press the **UP ARROW** or **DOWN ARROW** to increase or decrease the value of the flashing digit.
3. Press **NEXT** to move to the next digit.
4. After entering the Access Code, press **ENTER**. **STOREd** is displayed confirming your selection.
5. Press **NEXT** to return to the top of the menu system or press **RESET** to exit the menu system.

TIP:

If you forget the **Access Code**, set the DIP switch SW2 pole 4 to the **OFF** position to disable the access code (lockout). A new **Access Code** can be entered as described above. Lockout can be reactivated by turning switch 4 back on.

Section 2

2.0 Advanced Features

2.1 DIP Switch Settings

DIP switches are located on the bottom of the controller. Various functions are controlled by these switches. See TABLE 4 for the function for each switch position. See **FIGURE 7** for a picture of the DIP Switch.

TABLE 4 DIP Switch Settings

Pole Position	Function	Description
Pole 1	Analog Retransmission Calibration	Set switch to ON position to calibrate retransmission board, see. <i>Adjust Output Signal Section 2.2.3</i>
Pole 2	System Initialization and Calibration	This switch position should always be in the OFF position. NOTE: Contact the factory for further information.
Pole 3	Audible Alarm	When set to the ON position, the horn is enabled to sound.
Pole 4	Setup Protection	When set to the ON position, the controller checks the access code to verify the user can access the menu system.

SW4

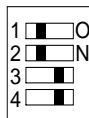

FIGURE 7 DIP

2.2 Analog Retransmission Option

The **Analog Retransmission Option** provides an analog output proportional to the process variable being displayed by the controller (e.g., the level in the tank). The retransmitted output signal does not have to be the same as the input signal. For example, the controller could accept a 4 to 20 mA input and provide a 0 to 10 volt output. The retransmitted signal is scaled with respect to the displayed process value. Any linearization applied to the input is incorporated into the retransmitted signal. The two process values that define the end points of the retransmitted signal are set using the menu system. This allows the input and retransmitted signals to have different ranges (i.e., a 4 to 20 mA input could represent a level of 0 to 23.1 ft. with the retransmission scaled to output 4 mA at 1 ft. and 20 mA at 21 ft.).

To access the menu to configure analog retransmission:

1. Press NEXT repeatedly to navigate to ANALOG REXMIT.
2. Press ENTER.

NOTE:

The resolution of the output signal is only as good as the resolution of the display and will never be better than 0.05% of the output span.

2.2.1 Card Configuration

The **DIP** switches on the retransmission card are used for setting the output range of the Card. The final calibration is done through the menu system, see *sections 2.2.2 and 2.2.3*. To access the analog retransmission card, unplug the two rear terminal blocks and remove the back plate. Set the DIP Switches to configure the card for a maximum output of 5V, 10V, or 20mA. See **FIGURE 8** and TABLE 5 for DIP Switch settings.

NOTE:

The retransmitted signal does not have to be the same type of signal as the input (e.g., a 0/10V input can be retransmitted as a 4/20mA signal).

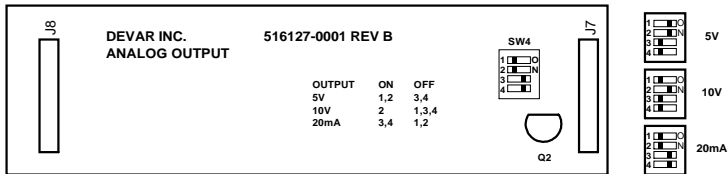

FIGURE 8 Analog Retransmission Card

TABLE 5 Output Settings

Output	ON	OFF
5V	1, 2	3, 4
10V	2	1, 3, 4
20mA	3, 4	1, 2

2.2.2 Set Output Values

The user must define the process value that appears on the display to produce the minimum retransmitted output (e.g., 4 mA.) and the process value that produces the maximum retransmitted output, e.g. 20 mA.

1. Navigate to the ANALOG REXMIT prompt and press ENTER.
2. The dISPLY@MIN OUTPUT prompt appears
3. Press ENTER. The current setting appears.
4. Press the UP ARROW or DOWN ARROW to increase or decrease the value of the flashing digit.
5. Press NEXT to move to the next digit.
6. After changing all the digits, press ENTER to save the setting. STOREd is displayed confirming your selection.
7. The dISPLY@MAX OUTPUT prompt appears Repeat steps 3 through 6 for the dISPLAY@ MAX OUTPUT menu item.

NOTE:

The default factory calibration for analog retransmission is a 4 to 20 mA output for a 0 to 100% input.

2.2.3 Adjust Output Signal

The analog retransmission board is calibrated using the **TRIM MIN OUTPUT** and **TRIM MAX OUTPUT** menu items. This is a factory calibration and does not have to be performed on new units unless the DIP switch settings are being changed on the retransmission card. The output of the analog retransmission board is controlled by sending it a number. The number can range from 0 to 4095; the larger the number, the larger the output. Calibration consists of adjusting the number up or down to increase or decrease the measured output level.

NOTE:

The TRIM MIN OUTPUT and TRIM MAX OUTPUT menu prompts only appear when DIP switch, SW4, Pole 1 is in the ON position (See *Section 2.1*).

To adjust the output signal:

1. Connect an appropriate meter (voltage or milliamp) to the analog output terminals on the rear panel.
2. Navigate to the ANALOG REXMIT prompt then press ENTER.
3. Press NEXT Until the TRIM MIN OUTPUT prompt appears then press ENTER.
4. The number controlling the output signal for this calibration point is displayed.
5. Press the UP ARROW or DOWN ARROW to increase or decrease the value of the flashing digit.
6. Changing the value of the displayed number will cause a decimal point to appear. When the decimal point is present, the number is in the edit mode and is no longer controlling the output. Pressing NEXT or ENTER will update the analog output and remove the decimal point.

7. With the decimal point removed pressing NEXT moves to the next digit to edit. Changing the number will cause the decimal point to reappear. Pressing NEXT or ENTER will once again update the analog output and remove the decimal point.
8. Repeat steps 5 through 7 until the analog output reaches the proper value.
9. Press ENTER, STOREd is displayed confirming your selection.
10. The TRIM MAX OUTPUT prompt appears.
11. Repeat steps 4 through 9 for the TRIM MAX OUTPUT menu item.

2.3 Non Standard Inputs

A standard input is any input in which the displayed process varies linearly with the input signal. A linear curve is defined by its two end points as described in sections 1.4.4 and 1.4.5. All other inputs are nonstandard.

2.31 Square Root Response

A square root response is a nonlinear curve in which the displayed process varies as the square root of the input signal. The user must specify the top of the range. The starting point is always zero, (e.g., 4 to 20 mA represents 0 to 2000 gpm).

1. Follow the display setup procedure, *sections 1.4 through 1.4.3*.
2. At the INPUT OUTPUT CURVE prompt, Press ENTER. The current setting appears.
3. Press the UP ARROW or DOWN ARROW to select SQUARE ROOT.
4. Press ENTER, DEFINE MAX RANGE appears
5. Press ENTER, The current setting appears.
6. Press the UP ARROW or DOWN ARROW to increase or decrease the value of the flashing digit.
7. Press NEXT to move to the next digit.
8. After changing all the digits, press ENTER to save the setting. STOREd is displayed confirming your selection.

2.32 Custom Input Curve

The custom curve function allows you to approximate a nonlinear, signal to process curve, by using up to 16 straight-line segments. The straight-line segments are defined by entering a series of break points, labeled from "BP 0" to "BP 16." When entering break points, first define at what percentage of the input the break point falls, then define the desired process value at that break point. Breakpoints can be located between 0% and 100% of the input range. Breakpoints that are located at percentages above 100% will be removed from the list of active breakpoints. If there are less than 17 breakpoints, more can be added by pressing ENTER at the ADD BREAKPOINT prompt. Breakpoints can be edited or added in any order. The program will sort the breakpoints into an ascending order after the entry is completed.

1. Press NEXT until SETUP DISPLAY appears, press ENTER.
2. Press NEXT until INPUT OUTPUT CURVE appears. Press ENTER.
3. Press UP ARROW or DOWN ARROW until CUSTOM CURVE appears. Press ENTER. STOREd is displayed confirming your selection.
4. To set a breakpoint, press ENTER at the BP(n) prompt, or press NEXT to move on to the next break point, BP(n+1).
5. At INPUT % at BP(n) prompt, press ENTER.
6. Press NEXT and UP ARROW or DOWN ARROW to set the location of BP(n) between 00.00% and 100.00%. Press ENTER. OKAY is displayed confirming your selection.
7. At the dISPLAY at BP(n) prompt, press ENTER.
8. Press NEXT and UP ARROW or DOWN ARROW to set the display to the desired process value at BP(n). Press ENTER. STOREd is displayed confirming your selection.
9. If you have defined fewer than 17 breakpoints, the ADD BREAKPOINT prompt appears. Press ENTER to add another break point or press NEXT to return to the SETUP dISPLAY prompt.
10. Repeat steps 4 through 9 until all the break points have been defined.

NOTES:

- 1 No two breakpoints can have the same *input percentage* but they can have the same *output value*.
- 2 There cannot be less than 2 or more than 17 break points.
- 3 Use the NEXT key to skip over breakpoints that do not need to be changed.
- 4 To delete breakpoints that have already been added, set the process value above 100% at the INPUT % at BP(n) prompt.
- 5 Use the RESET key to exit the custom curve configuration and return to the SETUP dISPLAY prompt.

Section 3

3.0 Frequently Asked Questions

Question:	Answer:
If my tank is 10 feet deep should I set my "define maximum range" to 10 feet?	No. The "define maximum range" and the "define minimum range" should be set to match the output of the signal transmitter. For example, if you are using a 5 lb pressure transducer, set the minimum to 0 ft and the maximum to 11.5 ft.
What do I do if the pressure transducer is not located at the bottom of the tank?	Calibrate the controller to match the range of the transducer (e.g. 0 to 11.5 ft.), then use the "adjust offset" feature to correct for the position of the transducer.
How do I indicate the depth of water in my well, if the transmitter output is reverse acting, (the output goes down as the well fills up)?	An ultrasonic transmitter might output 4 mA at a distance of 25 ft and 20 mA at a distance of 1.5 ft. Set the "define maximum range" to 1.50 ft and the "define minimum range" to 25.00 ft. then use the "adjust offset" feature to compensate for the height of the Transmitter above the well.
If I have two alternating pumps should the trip and reset points for both pumps be set to the same level?	No. This will cause both pumps to turn on at the same time. One pump must be set to turn on at a higher level than the other. The pumps will alternate around the first trip point. If the second trip point reached, both pumps will turn on. The reset points can be set to the same value.
The controller seems to operate properly regardless of how the "failsafe polarity" is set. Is this an important setting?	Yes. This setting determines what happens if there is a loss of power to the controller. Setting the failsafe to "fail reset" for a pump control will turn the pump off on power loss. Setting the failsafe to "fail tripped" for an alarm will activate the alarm on power loss.

Frequently Asked Questions (cont.)

Question:	Answer:
<p>Why are the pumps being turned on when the controller is not in the tripped state?</p>	<p>The relay contacts may be wired incorrectly. Relay action is affected by the "failsafe polarity" setting. For "fail tripped," the pole and NC contact are closed in the tripped state. For "fail reset," the pole and NO contact are closed in the tripped state.</p>
<p>I have a nonlinear response programmed into the controller. Can I compensate for a change in the position of the pressure transducer by using the "adjust Offset" function?</p>	<p>No. You must generate a new custom curve, linearization table, defining the relationship between the level and the shifted transducer output.</p>
<p>How can I save time while navigating through the menu system?</p>	<p>Repeatedly press the NEXT button to skip past menu items that do not need to be changed. Use the RESET button to jump from a sub-menu prompt back to the main menu. Use the RESET button to jump from the main menu back to displaying the measured process.</p>
<p>Why did my analog retransmission stop working properly after the controller was reconfigured for a different tank level?</p>	<p>The analog output is not a function of the input signal (e.g., 4 to 20 mA) but is defined by the tank levels which appear on the display. If the display configuration is changed, the analog retransmission will have to be reconfigured.</p>

Section 4

4.0 Error Codes/ Troubleshooting

Error:	Description:
+ OVER	Appears when trying to display a value outside of the numeric range of the meter, i.e., greater than 9999. If this message appears, verify that the input signal is valid, that the input is wired correctly and that the input defined at "Select Input Type" matches the signal being applied to the controller.
- OVER	Appears when trying to display a value outside of the numeric range of the meter, i.e., less than -1999. If this message appears, verify that the input signal is valid, that the input is wired correctly and that the input defined at "Select Input Type" matches the signal being applied to the controller.
No A/D	The analog to digital converter is not communicating with the microcontroller. If this message appears, try cycling power to the unit. If this does not solve the problem, the unit has been damaged and should be returned for repair.
EEPROMERROR	The microcontroller is receiving invalid data from the EEPROM. If this message appears, try cycling power to the unit. If this does not solve the problem, the unit has been damaged and should be returned for repair.
DUPLICATE ENTRY	When configuring a custom input curve, this message will appear if you attempt to define two breakpoints at the same input percentage.
NOT ENOUGH VALID BREAK POINTS	When configuring a custom input curve, this message will appear if only one break point has been defined. A custom curve can have any number of breakpoints between 2 and 17.
DENIED	This message appears if you have entered an invalid access code when trying to enter the menu system. If you have forgotten the access code, refer to <i>Section 1.2</i> of this manual.

Section 5

5.0 Specifications

Power Requirement	90-140VAC Single Phase 50/60Hz or 130-190VDC, 10 VA max
Operating Temperature	0°C to 70°C
Dimensions	
Front Bezel	48mm H x 96mm W x 12mm
Panel Cutout	45mm H x 91mm W
Overall	48mm H x 96mm W x 166mm D
Environmental Rating	Type 1, Splash resistant front panel
Weight	0.522Kg = 1.15lbs. = 18.4oz
Display	Six characters, 0.54" high, 15 segment, Alpha-Numeric, high efficiency red LED
User Input	Four button integrated membrane switch front panel keypad
Output Relay	SPDT (form C) relays; 1 Phase; 7.5A at 240VAC/24VDC; 1/3 HP at 120VAC (7.2 FLA); ½ HP at 240VAC (4.9 FLA)
Max Terminal Screw Torque	7 lb./in.
Relay Operation	<ol style="list-style-type: none">1) Relay de-energizes on power failure, which causes closure between P and NC. An energized relay has closure between P and NO.2) A failsafe polarity of FAIL TRIPPED de-energizes the relay in the alarm (tripped) condition, the LED is lit. A failsafe polarity of FAIL RESET de-energizes the relay in the non-alarm (reset) condition, the LED is dark.3) When enabled, detected sensor failure will cause all relays to go to the selected states, either tripped or reset.
Loop Power Supply Isolation Strength	24V @ 100mA MAX, 150mA short circuit 500VAC to input terminals or earth
INPUT	
A/D converter	24 bit Delta-Sigma type
Reference	2.5V ±15ppm / °C typical
Voltage Input Impedance	1M Ohms
Current Input Impedance	10 Ohms

5.0 Specifications (cont.)

-3dB frequency	12Hz.
Acceptable inputs	$\pm 10V$, 0/10V, 0/5V, 1/5V, 0/20mA, 4/20mA, 0/1 V
Display update rate	2 Hz
Accuracy	$\pm 0.01\%$ of span ± 1 count
INDICATION	
Displayable numeric range	-1999 to 9999 with decimal point to right of any digit
Scaling linear response	Define process values at minimum and maximum signal input
Scaling square root response	Define process value at maximum signal input
Linearization error:	< 0.5% for input below 1% of full scale, < 0.001% otherwise
Scaling custom curve	User defines 2 to 17 values at a percentage of input level.
OPTIONAL ANALOG RETRANSMISSION	
D/A converter	12 bits
Available full scale outputs	5V, 10V, 20mA
Accuracy relative to display	<0.05% of full scale output, see section 2.2
AGENCY APPROVALS	



51 JB

INDUSTRIAL CONTROL EQUIPMENT

Appendix

A.1 Field Wiring

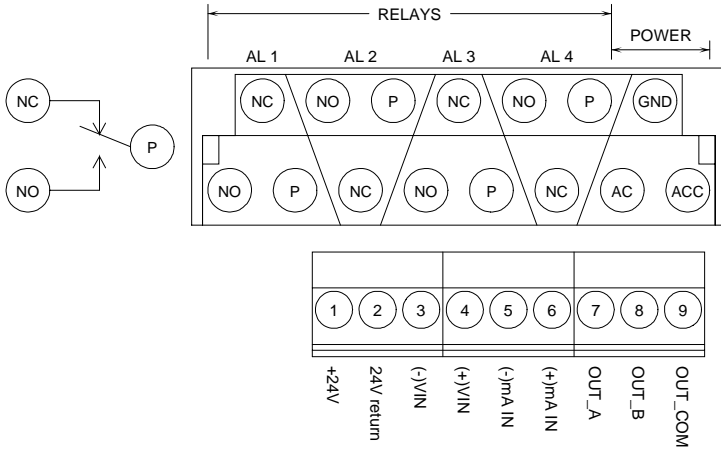
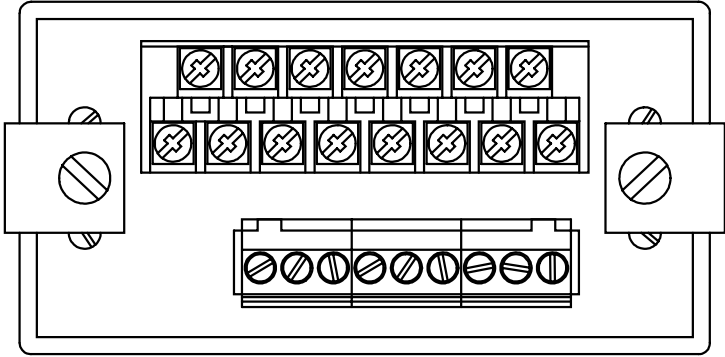

POWER: 90/140 VAC 50/60 Hz OR 130/190 VDC
 ACC = AC NEUTRAL OR DC RETURN
 AC = AC HOT OR \pm DC (FUSED LINE)

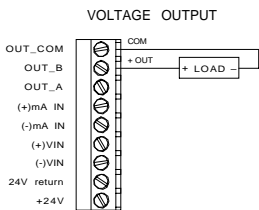
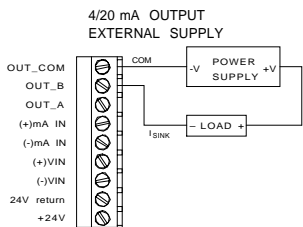
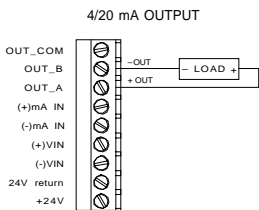
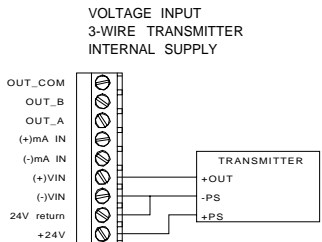
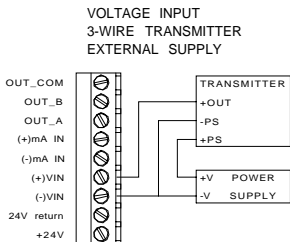
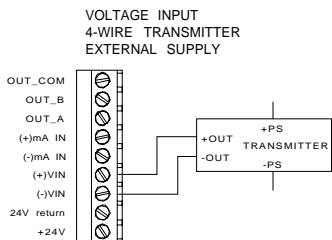
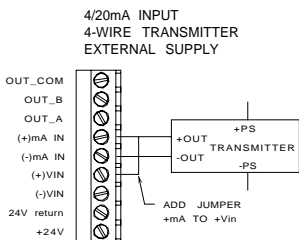
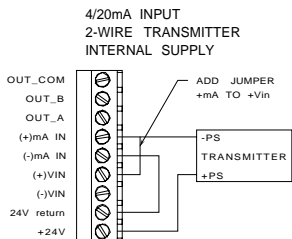
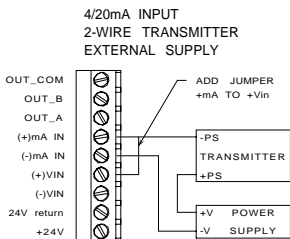

A.2 Menu Flowchart

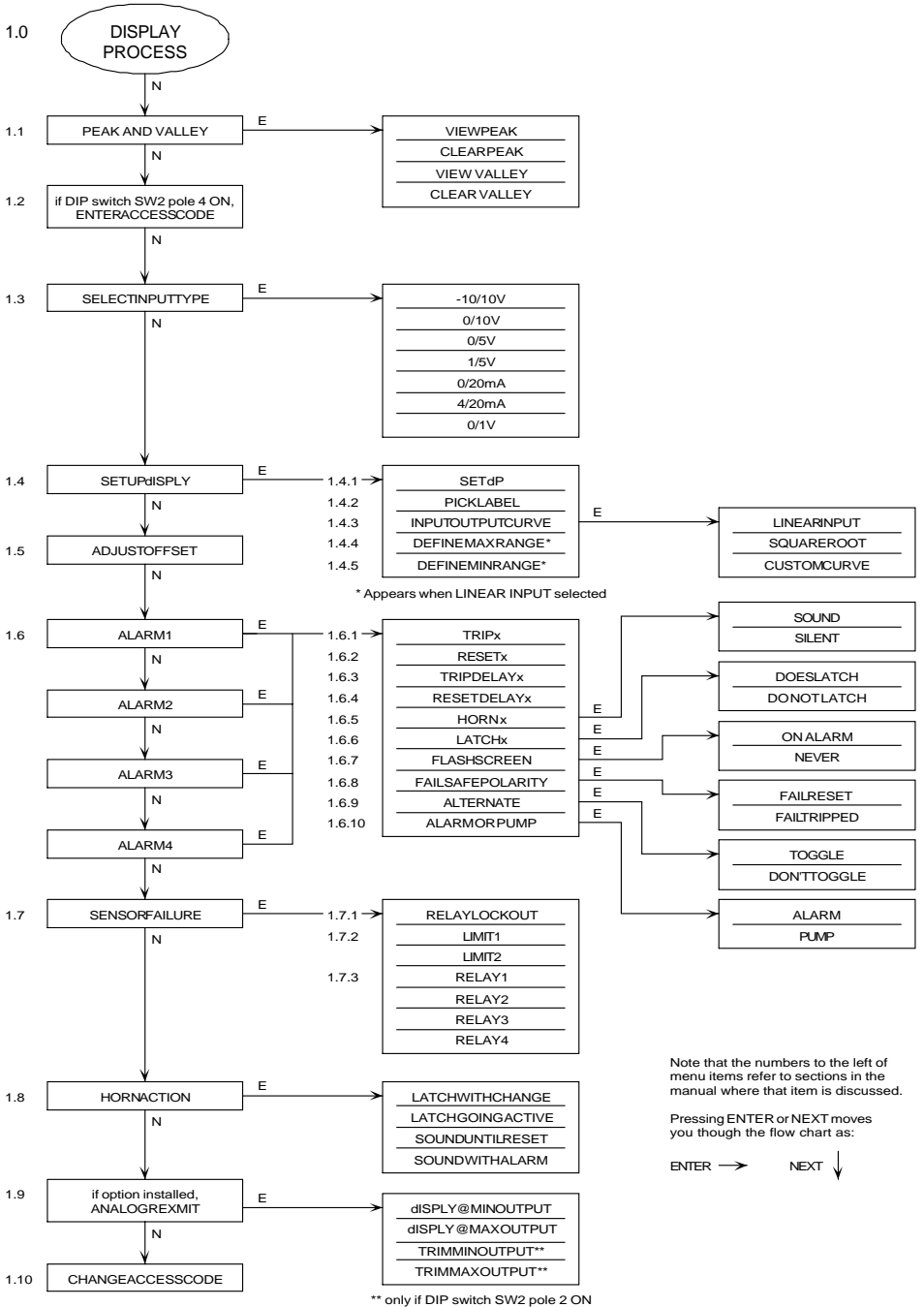

** only if DIP switch SW2 pole 2 ON

A.3 Typical Configuration Example

Project Specifications:

1. 10 ft Wet Well, Pump Down Application
2. (1) High and (1) Low Alarm
3. (2) Alternating Pumps
4. 5 lb (11.5 ft H₂O) Pressure Transmitter, 4 to 20 mA, Two Wire
5. Transmitter Located 1 ft Above Bottom of Well

Configuration Worksheet				
Transmitter Signal Range	0 To 11.5 ft of Water			
Select Input Type (1.3)	4 to 20 mA			
Set Decimal Point (1.4.1)	0 1 2 . 3 4 5			
Select Process Label (1.4.2)	FT			
Select Input/Output Curve (1.4.3)	Linear			
Define Maximum Range (1.4.4)	11.50 ft			
Define Minimum Range (1.4.5)	0.00 ft			
Adjust Offset (1.5)	1.00 ft			
Set Control/Alarm Points (1.6)	CHANNEL 1	CHANNEL 2	CHANNEL 3	CHANNEL 4
Trip Settings (1.6.1)	8.00 ft	8.50 ft	8.75 ft	1.50 ft
Reset Settings (1.6.2)	2.00 ft	2.00 ft	8.00 ft	2.00 ft
Trip Delay Settings (1.6.3)	0 sec	0 sec	15 sec	15 sec
Reset Delay Settings (1.6.4)	0 sec	0 sec	0 sec	0 sec
Horn Settings (1.6.5)	Silent	Silent	Sound	Sound
Latching Alarm Settings (1.6.6)	Never	Never	On Alarm	On Alarm
Fail Safe Polarity Settings (1.6.8)	Fail Reset	Fail Reset	Fail Tripped	Fail Tripped
Alternation Settings (1.6.9)	Toggle	Toggle	Don'tToggle	Don'tToggle
Alarm/Pump Settings (1.6.10)	Pump	Pump	Alarm	Alarm
Sensor Failure, Limit Settings (1.7)	Limit 1 = 0.5 ft Limit 2 = 13.0 ft			
Sensor Failure, Relay Setting (1.7)	Reset	Reset	Tripped	Tripped
Access Code (1.10)	000000			

A.4 Typical Configuration Worksheet

Project Specifications:

1. _____
2. _____
3. _____
4. _____
5. _____

Configuration Worksheet				
Transmitter Signal Range				
Select Input Type (1.3)				
Set Decimal Point (1.4.1)	0 1 2 3 4 5			
Select Process Label (1.4.2)				
Select Input/Output Curve (1.4.3)				
Define Maximum Range (1.4.4)				
Define Minimum Range (1.4.5)				
Adjust Offset (1.5)				
Set Control/Alarm Points (1.6)	CHANNEL 1	CHANNEL 2	CHANNEL 3	CHANNEL 4
Trip Settings (1.6.1)				
Reset Settings (1.6.2)				
Trip Delay Settings (1.6.3)				
Reset Delay Settings (1.6.4)				
Horn Settings (1.6.5)				
Latching Alarm Settings (1.6.6)				
Fail Safe Polarity Settings (1.6.8)				
Alternation Settings (1.6.9)				
Alarm/Pump Settings (1.6.10)				
Sensor Failure, Limit Settings (1.7)	Limit 1 =		Limit 2 =	
Sensor Failure, Relay Setting (1.7)				
Access Code (1.10)				

A.5 Custom Curve Configuration Example

Project Specifications:

1. 5000 Gallon, 8 ft Diameter, Horizontal Tank
2. Contents: Fuel Oil, Specific Gravity = 0.875
3. 5 lb (11.5 ft H₂O) Pressure Transmitter, Located at Bottom of Tank
4. Linearize to display Process In Gallons

% TRANSMITTER OUTPUT = (% TANK LEVEL) X (8 Ft/11.5 Ft)

% OUTPUT CORRECTED FOR SPECIFIC GRAVITY = (% TRANSMITTER OUTPUT) X (0.875)

Tank Level		Transmitter Output	
%	FEET	% (H ₂ O)	% (OIL)
0	0.00	0.00	0.00
3	0.24	2.09	1.83
6	0.48	4.17	3.65
10	0.80	6.96	6.09
15	1.20	10.43	9.13
20	1.60	13.91	12.17
25	2.00	17.39	15.22
35	2.80	24.35	21.30
65	5.20	45.22	39.57
75	6.00	52.17	45.65
80	6.40	55.65	48.70
85	6.80	59.13	51.74
90	7.20	62.61	54.78
94	7.52	65.39	57.22
97	7.76	67.49	59.04
100	8.00	69.57	60.87

TABLE (2.3.2) Custom Curve Configuration		
BP	% INPUT @ BP	DISPLAY @ BP
0	0.00	0000
1	1.83	0044
2	3.65	0122
3	6.09	0260
4	9.13	0470
5	12.17	0712
6	15.22	0978
7	21.30	1560
8	39.57	3440
9	45.65	4022
10	48.70	4288
11	51.74	4530
12	54.78	4740
13	57.22	4878
14	59.04	4956
15	60.87	5000
16		

A.6 Custom Curve Configuration Worksheet

Project Specifications:

1. _____
2. _____
3. _____
4. _____

TABLE (2.3.2) Custom Curve Configuration		
BP	% INPUT @ BP	DISPLAY @ BP
0		
1		
2		
3		
4		
5		
6		
7		
8		
9		
10		
11		
12		
13		
14		
15		
16		

Warranty Information

DEVAR INC. WARRANTS THIS PRODUCT AGAINST FAILURE AS A RESULT OF DEFECTS IN MATERIAL OR WORKMANSHIP FOR A PERIOD OF TWO YEARS. Should this product prove to be defective in material or workmanship during the warranty period, Devar Inc. will, at its discretion, repair or replace the defective item at no charge to the customer. Products that are damaged by accident, misuse, fire, water, lightning or other acts of nature are not covered under this warranty. Also not covered, is damage, due to shipping, installation, incorrect wiring or any other cause not related to a product defect. Unauthorized product modification, repair or attempted repair, or serial number modification will void the warranty.

DEVAR Inc.

706 Bostwick Ave
Bridgeport CT 06605 U.S.A.
800 566 6822, www.devarinc.com

MODEL 3020 Rev.C