

# DEVAR Inc. SUBMERSIBLE PRESSURE TRANSDUCER SERIES 700

- \* HIGH STATIC ACCURACY & REPEATABILITY
- \* WELDED 316 SS CONSTRUCTION
- \* SMALL RUGGED PACKAGE
- \* USER-SPECIFIED PRESSURE RANGES AVAILABLE
- \* 100% COMPUTER-TESTED, CALIBRATED AND SERIALIZED
- \* UNIQUE CABLE SEAL SYSTEM
- \* FULLY TEMPERATURE COMPENSATED
- \* DATA LOGGER COMPATIBLE



- \* Well Monitoring
- \* Slug Tests
- \* Pump Control
- \* Ground Water Monitoring
- \* Soil Remediation
- \* Oceanographic Research
- \* Lift Stations
- \* Level Control
- \* Surface Water Mounting

## GENERAL DESCRIPTION

The Series 700 family of submersible pressure transducers is specifically designed to operate under the rigorous conditions encountered in liquid level measurement and control. They provide dependable, accurate pressure or level measurements under the most adverse of operating conditions.

These transducers combine the latest advances in piezoresistive pressure sensing technology with an isolated, stainless steel, barrier diaphragm, which is used to contact the measured media. The transducers are housed in rugged, all-welded, corrosion resistant, 316 stainless steel housings. Titanium housings are also available for extremely corrosive media. High reliability, surface mount technology is used to provide precision signal conditioning with a power supply rejection of 0.001%.

These Transducers are available as 2-wire,

loop powered devices with 4 to 20 mA outputs or as 3-wire DC powered devices with 0 to 5VDC outputs.

Approvals to FM, CSA and UL are available for Class I, Div 1, Groups A, B, C and D, and Class II, Div 1, Groups E, F and G and Class III, Div 1 hazardous locations. These instruments also meet CE approval according to EN-50081-2 and EN-50082-2. Hazardous location installations must be made in accordance with local and national electrical codes and installed with an approved electrical barrier.

Each transducer is shipped with a desiccant canister or an optional Aneroid Bellows that prevents moisture from entering the cable vent tube. Also provided with each transducer is a traceable calibration card, specifying the input/output conditions and actual data recorded during testing.

**SPECIFICATIONS**

**PERFORMANCE:**

Range: 0-2 to 0-300 PSIG  
 Accuracy<sup>1</sup>: " 0.10 % FSO BFSL (730)  
 " 0.25 % FSO BFSL (720)  
 " 0.50 % FSO BFSL (710)  
 " 1.00 % FSO BFSL (700)  
 Thermal Error<sup>2</sup>: " 0.05 % FSO/°Cmax.(710,720, 730)  
 " 0.10 % FSO/°Cmax.(700)  
 Proof Pres.: 1.5 X rated pressure  
 Burst Pres.: 2.0 X rated pressure  
 Resolution: Infinitesimal

**ENVIRONMENTAL:**

Comp. temp. range<sup>3</sup> 0° to 50°C (710,720,730)  
 10° to 30°C (700)  
 Operating temp. range: -10° to 60°C

**ELECTRICAL:**

Excitation: 9 to 30 VDC  
 Input Current: 20 mA max. (2-wire)  
 3.5 mA max. (3-wire)  
 Output: 0-5 VDC (3-Wire)  
 4-20 mA (2-Wire)  
 Zero offset: +60 mV max. (0-5 V)  
 +0.12 mA max. (4-20 mA)  
 Output impedance (0/5 V): 5.1 K ohm  
 Max output load (4/20 mA):  
 { Resistance in Ohms = (supply voltage - 9) / 0.02 }  
 Insulation resistance: > 100 megohms at 50 VDC  
 Circuit protection: Polarity, surge, shorted output  
 Power supply rejection: < +.001% FSO/VDC

**PHYSICAL:**

Weight: 7 oz. (not including cable)  
 Cable: Shielded, 0.28" to 0.31" Dia.  
 Self-sealing Polyurethane jacket  
 (Tefzel jacket optional)  
 200 lb. pull strength

22 AWG conductors  
 polyethylene vent tube  
 810 vent filter/vapor trap  
 316stainless steel, Viton end  
 seal, PVC or Tefzel cable.  
 Suspended by cable; For  
 turbulent conditions, specify  
 optional mounting bracket.

Wetted materials<sup>4</sup>:

Mounting:

**Classification:**

These units are designed for installation in a Class 1, Division 1, Groups A,B,C and D, Class II, Division 1, Groups E, F, and G, Class III, Division 1, hazardous location when connected to the appropriate Stahl apparatus.

**Options:**

- TJVC Tefzel Cable
- AB Aneroid Bellows
- D Desiccant Canister
- 5CM 1/2" Male NPT Electrical Fitting
- 25PF 1/4" Male Pressure Fitting
- CH Cable Hanger
- T Titanium Housing
- TEMP Temperature Output (4/20 mA)
- PNC Ported Nose Cap (closed input face, 8-32 threaded hole)
- SA Sacrificial Anode

**Notes:**

1. Static accuracy includes the combined errors due to nonlinearity, hysteresis and nonrepeatability on a Best Fit Straight Line (BFSL) basis, at 25 degrees C per ISA S51.1.
2. Thermal error is the maximum allowable deviation from the Best Fit Straight Line (BFSL) due to a change in temperature, per ISA S51.1.
3. Tighter tolerances on static accuracy, thermal error and/or a wider compensated temperature range are available on request. Consult the Factory.
4. Titanium housings with hastelloy/platinum sensors are available for corrosive media. Consult the Factory.

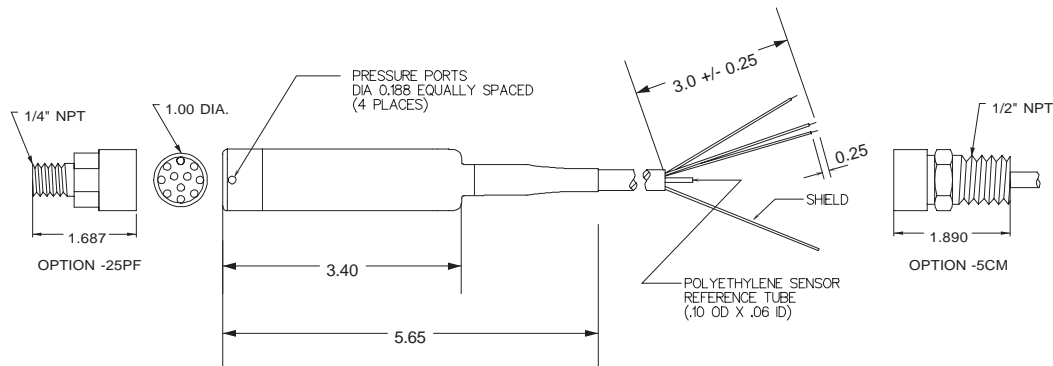

ELECTRICAL TERMINATION		
2 OR 3 24 AWG CONDUCTORS IN A SHIELDED CABLE WITH SENSOR BREATHER AND POLYURETHANE JACKET.		
4-20 mA	RED BLACK	+EXCITATION -EXCITATION
0-5 VDC	RED BLACK WHITE	+EXCITATION -EXCITATION SIGNAL

**DEVAR Inc.**

706 Bostwick Ave., Bridgeport, CT 06605-2396  
 TEL: 203-368-6751, 1-800-566-6822  
 FAX: 203-368-3747  
<http://www.devarinc.com>  
 e-mail: info@devarinc.com