

# DEVAR Inc.

706 Bostwick Avenue, Bridgeport, CT 06605  
203-368-6751 FAX 203-368-3747  
<http://www.devarinc.com> e-mail: [info@devarinc.com](mailto:info@devarinc.com)

## Model LD-LPI

LOOP POWERED  
INDICATOR



Manual No. 990629 5/02



# INSTRUCTION MANUAL

## LD-LPI LOOP POWERED INDICATOR

### General Description

The LD-LPI is a two-wire digital indicator that provides local process indication on a 3-1/2 digit liquid crystal display. The Indicator features 3-1/2, easy to read, 1 inch high active digits and a dummy zero. It is powered directly from the 4 to 20 mA input loop, dropping less than 1 volt across the input terminals.

The LD-LPI provides a digital readout directly proportional to the current input. The indicator is calibrated at the factory to read 0 to 100.0% for a 4 to 20 mA input, however, it can easily be recalibrated in the field to read directly in engineering units, such as temperature or flow. Each indicator comes with a selection of stick-on labels of commonly used engineering units such as GPM, PSI, etc.. These labels can be attached to the display so that a user can immediately determine what the indicator is reading.

Recalibration of the LD-LPI is easily accomplished through the use of switches and trim pots. The span can be adjusted from 0 to 3998 counts in three switch selectable ranges and the zero offset can be adjusted from -1999 to +1999 counts also in three switch selectable ranges. Fine adjustment of span and zero is made on two noninteractive 15 turn trim pots. Another feature of the LD-LPI is a nonactive (dummy) zero, which can be enabled or disabled by means of a DIP switch. One of four decimal point positions or no decimal point is also DIP switch selectable. The LD-LPI provides negative polarity indication, which appears when displaying quantities such as - 300 to 1000 ° F. The negative sign can, if desired, be disabled by means of a DIP switch.

An additional feature of the LD-LPI is the internal calibrator. The indicator can be field calibrated while installed in a working 4 to 20 mA loop, regardless of the current through the loop, simply by switching into the calibrate mode. The indicator can also be calibrated on the bench by using a conventional calibrator or by connecting a 1 to 1.5 volt power source (flashlight battery) across the input terminals and switching to the calibrate mode.

The LD-LPI is housed in a rugged, indoor/outdoor NEMA 4X, polycarbonate housing. This housing is corrosion resistant and dust-tight, and will withstand direct water spray under hose pressure. Options available include a 1/2 NPT water-tight conduit hub (Option M42), a panel mounting bezel (Option M46), a bracket for 2 inch pipe mounting (Option M36), a 3 inch snap-track mounting bracket (Option M31S) and DIN rail mounting bracket (option M31D).

### Specifications

1. Input
  - a. Range: 4 to 20 mA
  - b. Voltage drop: 0.98V @ 20mA, 25 ° C
  - c. Forward current over range: 100 mA max.
  - d. Reverse current: 100 mA max.
2. Display
  - a. Type: 3-1/2 digit LCD, with dummy zero, 1" high digits
  - b. Range: -1999 to 1999 counts
  - c. Decimal point: four positions or absent, switch selectable
  - d. Polarity sign: negative polarity indication or none, switch selectable
  - e. Action: forward acting (count increases with current), normal calibration; reverse acting (count decreases with current), obtained by appropriate zero setting
  - f. Over range indication: display blanks except for most significant 1
3. Calibration
  - a. Span range: 0 to 3998 counts, 3 ranges switch selectable, fine adjustment on 15 turn trim pot, noninteractive with zero pot
  - b. Offset range: -1999 to +1999 counts, 3 ranges switch selectable, fine adjustment on 15 turn trim pot, noninteractive with span pot
  - c. Resolution: better than 1 count
4. Performance
  - a. Accuracy:  $\pm 0.1\%$  of span counts,  $\pm 1$  count
  - b. Temperature effect (zero):  $\pm 0.1$  count / ° C
  - c. Temperature effect (span):  $\pm .01\%$  of span counts per ° C
  - d. Operating temperature: -30 to +85 ° C
  - e. Ripple rejection: less than 1 count with 1 mA peak-to-peak, 60 Hz ripple at input
  - f. Sample rate: 2 per second
5. Enclosure
  - a. Material: polycarbonate
  - b. Ratings: NEMA 4X, Flamability UL 94-5V

### **DEVAR Inc.**

706 Bostwick Ave., Bridgeport CT 06605-2396  
Tel: (203) 368 6751 Fax: (203) 368 3747  
www.devarinc.com E-Mail: info@devarinc.com

## **Field Wiring**

Field connections are made to a compression type terminal block located at the bottom of the enclosure. To expose the terminal block remove the cover from the enclosure, loosen the two screws at the corners of the PC board and remove the PC board from the enclosure. Terminals 1 and 2 are the positive and negative input terminals, terminal 3 is a spare which can be used as a tie point. The field wiring terminal block is connected to a two point terminal block located on the top left hand corner of the PC board. When bench testing the unit, input signals can be connected directly to the top terminal block without removing the PC board from the enclosure.

## **Initial Settings**

1. Set Input Voltage Drop (Factory Calibrated) : input 20 milliamps at the input terminals of the indicator. Adjust pot "P1" for a voltage drop of 0.95 volts between the input terminals.
2. Zero Adjustment (Factory Calibrated): To prevent the interaction of the span and zero pots the 4 milliamp off set is compensated for at the output of amplifier "U1". To do this, input 4 milliamps into the indicator, set switch position 2 to the normal operating position, and then adjust pot "P2" for 0.000 volts between pins 3 and 6 of amplifier "U1".
3. Calibration of Internal Calibrator (Factory Calibrated): Calibrate the display to read 00.0 to 100.0 for a 4 to 20 milliamp input following the instructions for calibrating the display. With the indicator operating (the value of the input current does not matter) switch switch 2, position 2 to the Activate Internal Calibrator position. Switch switch 2, position 1 to the Calibrate Zero position and adjust pot "P3", until the display reads 00.0. Switch switch 2, position 1 to the Calibrate Span position and adjust pot "P4" until the display reads 100.0. Return switch 2, position 2 to the Normal Operating position. Note that the input current has no effect on the display while switch 2 is in the Activate Internal Calibrator position.

## **Display Calibration**

To calibrate the LD-LPI, proceed as follows:

1. Determine desired display for a 4 to 20 mA input.  
Example: -30.0 to 195.0 o F
2. Set span switches S1-1 and S1-2 for the proper span range.  
Example: Span =  $1950 - (-300) = 2250$  counts;  
set S1-1 off, S1-2 off; (Note: ignore decimal point)



3. Set zero switches S1-3 and S1-4 for proper zero range.  
Example: Zero = -300 counts; set S1-3 off, S1-4 off
4. Select decimal point.  
Example: Select P3 decimal point; set S1-7 on, S1-5,6,8 off
5. Enable or disable negative polarity indication.  
Example: Enable negative sign; set S1-10 on
6. Enable or disable dummy zero.  
Example: Disable dummy zero; set S1-9 off
7. Input 4 mA and set "zero pot" for bottom of range.  
Example: Adjust zero pot to display -30.0
8. Input 20 mA and set "span pot" for top of range.  
Example: Adjust span pot to display 195.0
9. The indicator is now calibrated.  
Note that the dummy zero is not an active digit and should not be used when determining span and zero counts.

## **Using The Internal Calibrator**

The LD-LPI can be calibrated using the internal calibrator, while installed in a working loop, or it can be calibrated on the bench by connecting a 1 to 1.5 volt supply across the input terminals as a power source. To use the internal calibrator proceed as follows:

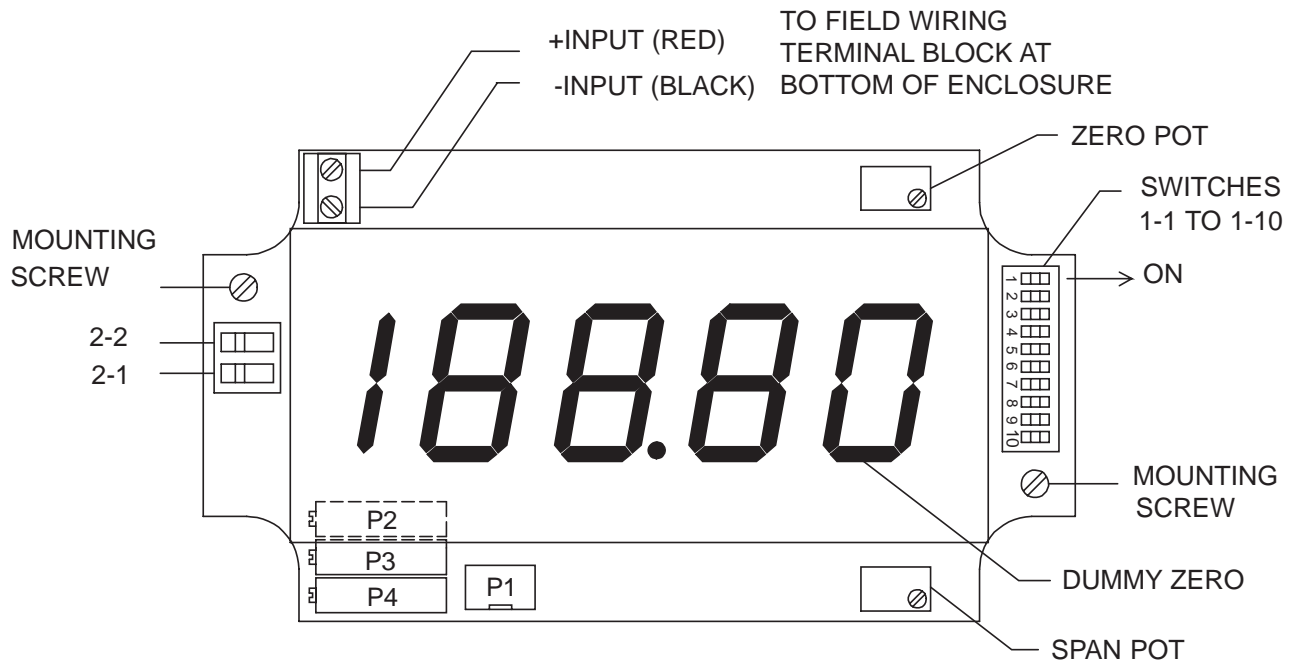
1. Set the calibrating switches for the desired span and offset ranges as described in the preceding section.
2. Set switch 2, position 2 to the Activate Internal Calibrator position.
3. Set switch 2, position 1 to the Calibrate Zero position, then adjust the "zero pot" until the bottom of the range is displayed.
4. Set switch 2, position 1 to the Calibrate Span position, then adjust the "span pot" until the the top of the range is displayed.
5. Return switch 2, position 2 to the Normal Operation position. The indicator is now calibrated.



NORM. OPERATION  ACTIVATE INTERNAL CALIBRATOR  
 CALIBRATE ZERO  CALIBRATE SPAN

DEPRESS TO ACTIVATE  SWITCH 2

**Fig. 1 PC Board Layout**

<b>S1-1</b>		<b>S1-2</b>	<b>SPAN RANGE</b>
OFF		ON	000 TO 1530 COUNTS
OFF		OFF	1530 TO 2470 COUNTS
ON		OFF	2470 TO 3998 COUNTS
<b>S1-3</b>		<b>S1-4</b>	<b>ZERO OFFSET</b>
ON		OFF	-573 TO -1999 COUNTS
OFF		OFF	-573 TO 573 COUNTS
OFF		ON	573 TO 1999 COUNTS
S1-5	ON	1.999_	SELECT DECIMAL POINT
S1-6	ON	19.99_	
S1-7	ON	199.9_	
S1-8	ON	1999._	
S1-9	ON	19990	ENABLE DUMMY ZERO
S1-10	ON	ENABLES NEGATIVE POLARITY INDICATION	

**Fig. 2 Switch Setting Table**

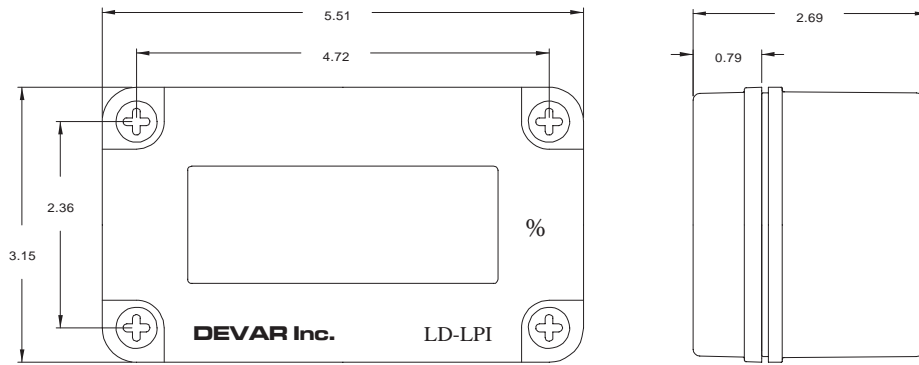

**Fig. 3 General Dimensions**

**Notes:**

1. Four mounting holes for # 6 screws are located directly below the cover screws.
2. Access to the enclosure can be made by drilling, punching or sawing holes into the long side of the enclosure. Locate center of access holes 7/8 of an inch in from the back side of the enclosure.

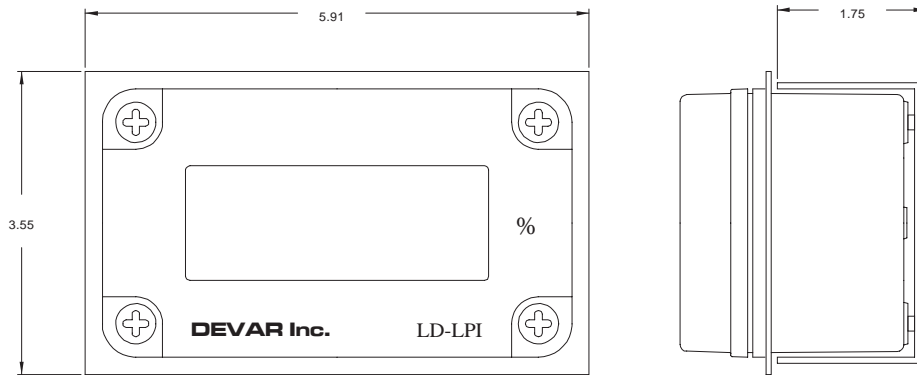

**Fig. 4 Panel Mount Dimensions**

Panel Cutout: 5.45 X 3.07 ±.015

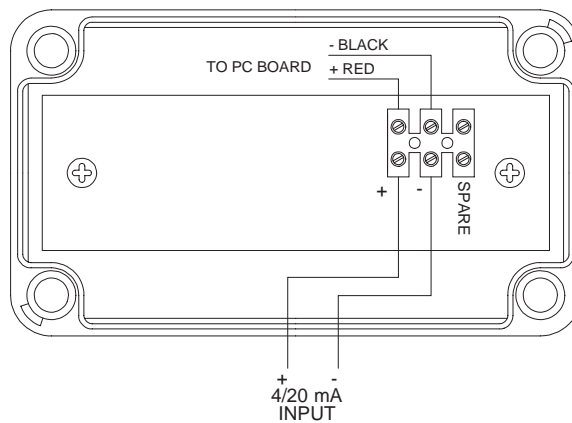

**Fig. 5 Field Wiring**

OPTION -LPS  
ADD INTERNAL LOOP POWER SUPPLY  
TO LD-LPI LOOP POWERED INDICATOR

The Model LD-LPI-LPS provides a regulated 24 volt DC power supply, which can be used to power an external 2-wire transmitter in a 4 to 20 mA instrumentation loop. The power supply features a split bobbin power transformer and output current limiting circuitry.

The 24 volt power supply is normally connected in series with the field transmitter, the loop powered indicator and any other loads in the 4 to 20 mA loop. A two position terminal block is provided for AC power and a six position terminal block is provided for connections between the transmitter, the indicator and the power supply.

Specifications:

Power. . . . .	105 to 125 V, 50/60 Hz ,5 VA 210 to 250 V, 50/60 Hz, 5 VA (Option E-71)
Output Voltage. . . . .	+ 24 VDC $\pm$ 1 V
Output Current. . . . .	25 mA, Internally Limited
Line Regulation. . . . .	0.004% per Volt Typ., 0.06% per Volt Max.
Load Regulation. . . . .	0.004% Typ., 0.04% Max.
Ripple. . . . .	20 mV P-P, Max.
Temperature Range. . . .	-40 to 85 °C
Temperature Effect. . . .	0.008% per °C, Typ.

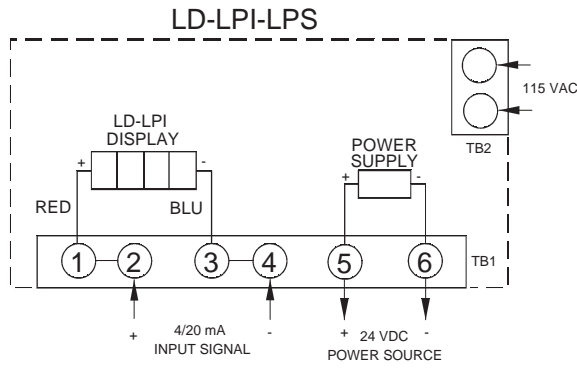

Fig. 1 Internal Wiring of LD-LPI-LPS

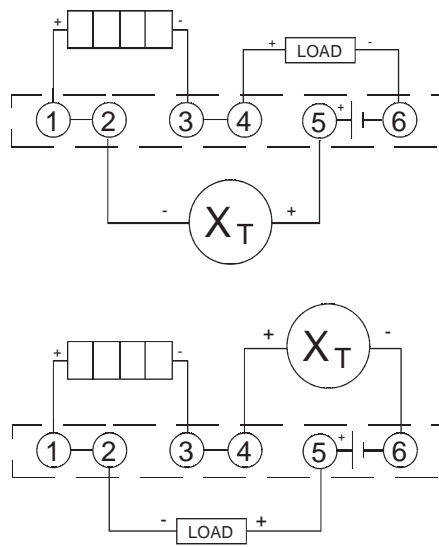

Fig. 2 Typical Wiring For 2-Wire Field Transmitter

OPTION -BL  
ADD BACK LIGHTING TO THE LD-LPI

Option BL adds back lighting to the LD-LPI display. This option allows the meter to be easily viewed in low light conditions as well as in normal light conditions. The back lighting derives its power from the 4 to 20 mA loop and adds a 2 volt burden to the loop. The total input voltage drop for the LD-LPI-BL is 3 volts at 20 mA.

DWG NO. 515107 SH 1

REV	DATE	DESCRIPTION	DATE	APPROVED
H	02-08-95	ADD 18-SLPI, 18-SLPI-IV AND 18-SLPI-SR, ECN 3081A	04-22-91	AG
I	01-22-98	ADD LD-LPI, ECN 3154	02-26-92	AG
J	09-09-99	ADD SM-822P-1, SM-822P-1T, SM-822P-2 & SM-822R, ECN 3208	02-07-95	AG
K	09-13-05	ADD LD-LPIX & -BL BACKLIGHT OPTION, ECN 3319		AG

**HAZARDOUS LOCATION**

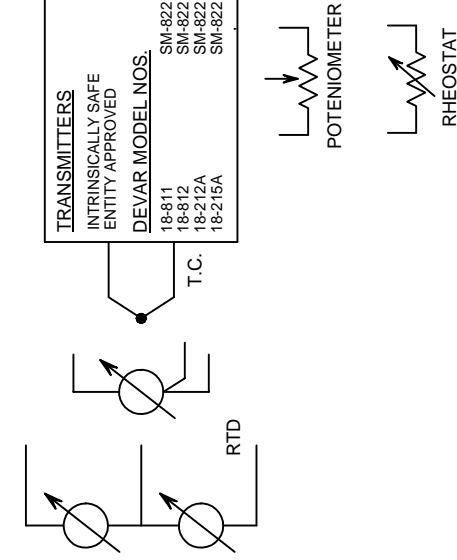

**NON-HAZARDOUS LOCATION**

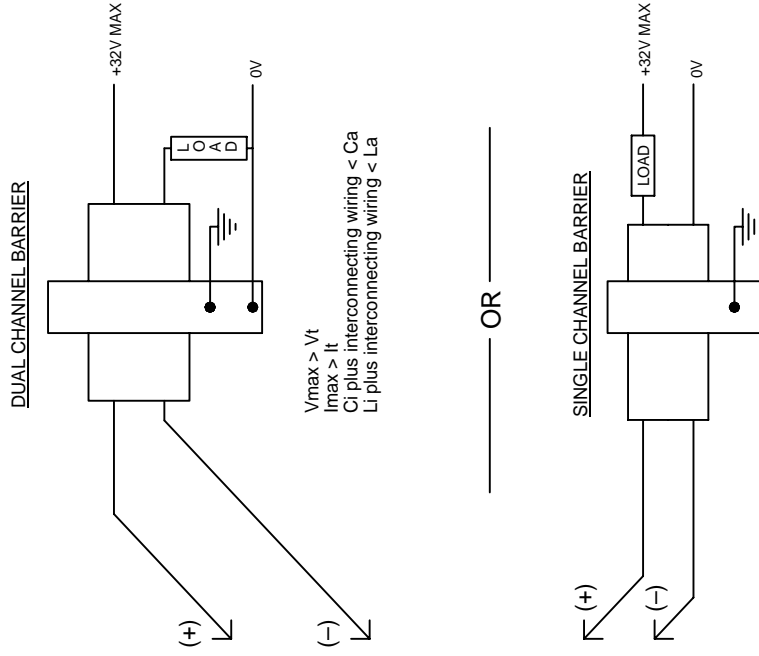

**NOTES:**

- HAZARDOUS LOCATION RATINGS: CLASS I, DIVISION 1, GROUPS A, B, C, D
- ENTITY PARAMETERS:  $V_{max} = 32\text{ V}$ ,  $I_{max} = 150\text{ mA}$ ,  $C_i = 0\text{ }\mu\text{F}$ ,  $L_i = 0\text{ mH}$
- INSTALLATION OF THE SYSTEM MUST BE IN ACCORDANCE WITH ANSI/ISA RP12.6
- CONTROL ROOM INSTRUMENTATION TO OPERATE AT LESS THAN 250V rms
- DO NOT CONNECT mA METER TO TRANSMITTER MONITOR TERMINALS UNLESS AREA IS KNOWN TO BE SAFE
- THE ABOVE UNITS ARE NONINCENDIVE FOR CLASS I, DIVISION 2, GROUPS A, B, C, D LOCATIONS WITH A  $V_{max}$  OF 32V. BARRIERS ARE NOT REQUIRED FOR DIVISION 2 OPERATION.
- NO REVISIONS WITHOUT PRIOR FACTORY MUTUAL APPROVAL

UNSPECIFIED DIMENSION TOLERANCE		CONTRACT NO.	
DECIMAL	+/- .0005"	PREPARED	08-16-05
ANGLE	+/- .166°	CHECKED	
MATERIAL	-N/A-	MECH	
FINISH	-N/A-	ELEC	
DESIGN		DESIGN	
APPROVED		APPROVED	
NEXT ASSTY NO.	NONE	SCALE	NONE
SIZE	B	DRAWING NO.	515107
REV	K	SHEET	1 OF 1

**DEVAR Inc.**  
706 Bostwick Avenue, Bridgeport, Conn. 06605  
TEL (203) 368-6751 FAX: (203) 368-3747

**INTERCONNECTING DIAGRAM TO INTRINSICALLY SAFE APPARATUS**



DWG NO. 515380		SH. 1	
D	ADD LD-LPI; ECN 3119	06-14-96	AG
A	PROPOSED	08-21-91	AG
B	RELEASE ECN 3031A	03-20-92	AG
C	ADD 18-SLPI-IV; ECN 3081A	02-13-95	AG

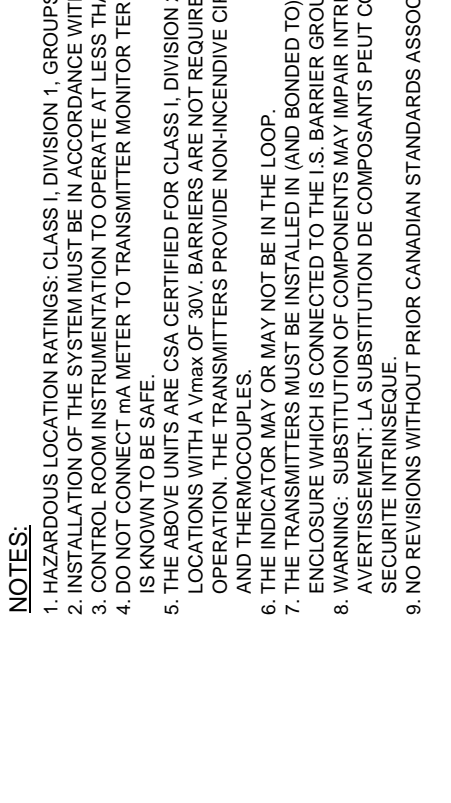
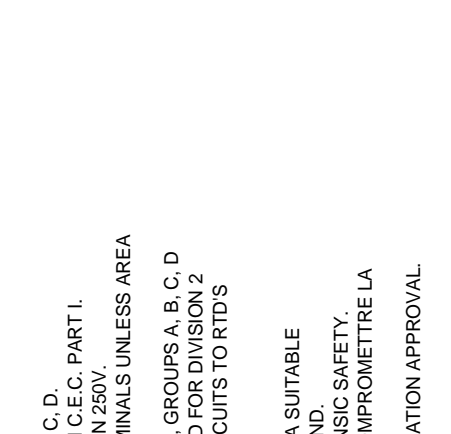
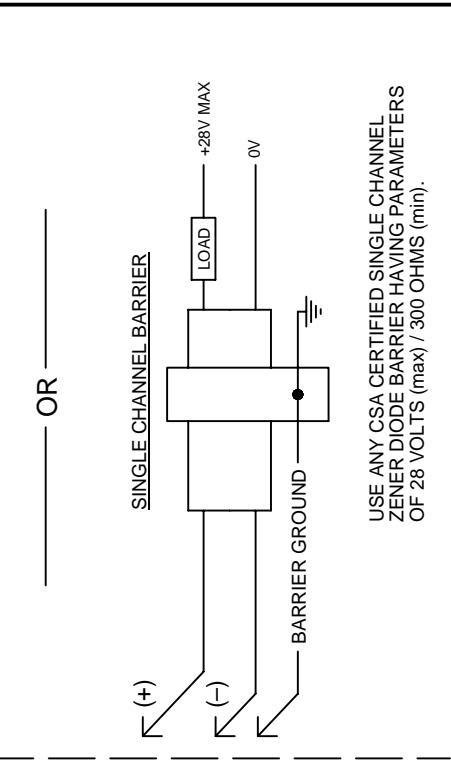
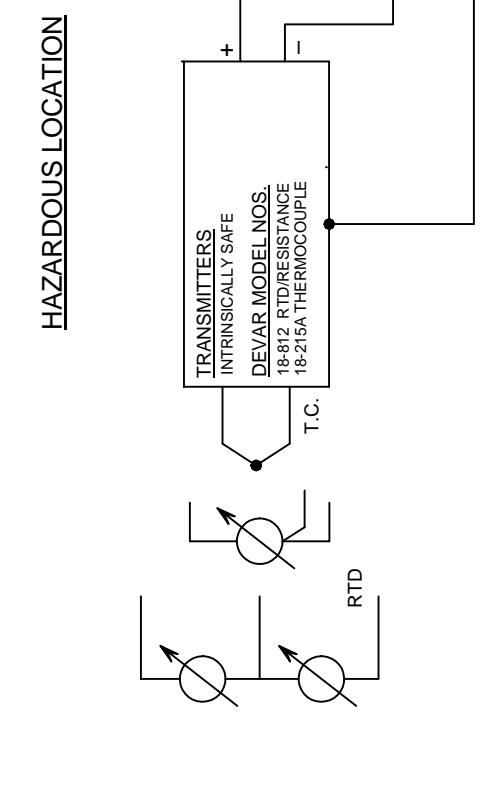
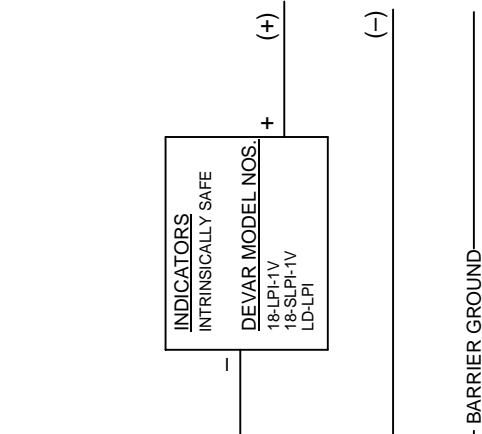
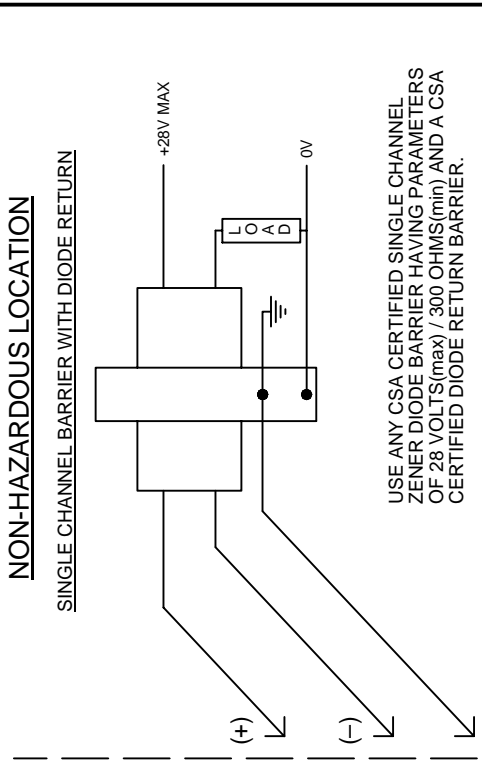

**NOTES:**

- HAZARDOUS LOCATION RATINGS: CLASS I, DIVISION 1, GROUPS C, D.
- INSTALLATION OF THE SYSTEM MUST BE IN ACCORDANCE WITH C.E.C. PART I.
- CONTROL ROOM INSTRUMENTATION TO OPERATE AT LESS THAN 250V.
- DO NOT CONNECT mA METER TO TRANSMITTER MONITOR TERMINALS UNLESS AREA IS KNOWN TO BE SAFE.
- THE ABOVE UNITS ARE CSA CERTIFIED FOR CLASS I, DIVISION 2, GROUPS A, B, C, D LOCATIONS WITH A  $V_{max}$  OF 30V. BARRIERS ARE NOT REQUIRED FOR DIVISION 2 OPERATION. THE TRANSMITTERS PROVIDE NON-INCENDIVE CIRCUITS TO RTD'S AND THERMOCOUPLES.
- THE INDICATOR MAY OR MAY NOT BE IN THE LOOP.
- THE TRANSMITTERS MUST BE INSTALLED IN (AND BONDED TO) A SUITABLE ENCLOSURE WHICH IS CONNECTED TO THE I.S. BARRIER GROUND.
- WARNING: SUBSTITUTION OF COMPONENTS MAY IMPAIR INTRINSIC SAFETY.
- AVERTISSEMENT: LA SUBSTITUTION DE COMPOSANTS PEUT COMPROMETTRE LA SECURITE INTRINSEQUE.
- NO REVISIONS WITHOUT PRIOR CANADIAN STANDARDS ASSOCIATION APPROVAL.

USE ANY CSA CERTIFIED SINGLE CHANNEL ZENER DIODE BARRIER HAVING PARAMETERS OF 28 VOLTS(max) / 300 OHMS(min) AND A CSA CERTIFIED DIODE RETURN BARRIER.

OR

USE ANY CSA CERTIFIED SINGLE CHANNEL ZENER DIODE BARRIER HAVING PARAMETERS OF 28 VOLTS (max) / 300 OHMS (min).

**NON-HAZARDOUS LOCATION**

SINGLE CHANNEL BARRIER WITH DIODE RETURN

**HAZARDOUS LOCATION**

UNSECURED DIMENSION TOLERANCE DECIMAL $\pm 0.005$ FRACTION $\pm 1/64$ ANGLE $\pm 1/2$ DEGREE	CONTRACT NO.	706 Bostwick Avenue, Bridgeport, Conn. 06605 TEL: (203) 368-6751 FAX: (203) 368-3747	
	PREPARED CHECKED MECH ELEC DESIGN APPROVED APPROVED	LH	08-21-91
MATERIAL			
FINISH			
NEXT ASSY NO.	AG	4-9-92	REV D
	B	DRAWING NO. 515380	SCALE NONE
	WT		SHEET 1 OF 1

This Drawing is the sole property of DEVAR Inc., and is submitted on the understanding that the contents hereof are not published and are not to be disclosed to third persons without prior permission.

